

PROVIDING SAFETY

WE PROTECT YOUR  
most valuable asset  
**YOUR WORKFORCE**



T +31 (0)10 822 44 00  
[www.usp-safety.com](http://www.usp-safety.com)





Smith Flow Control and  
Netherlocks have merged.  
We are now Sofis.  
[www.sofisglobal.com](http://www.sofisglobal.com)



**sofis**  
valve operation



**SMITH**  
FLOW CONTROL LTD

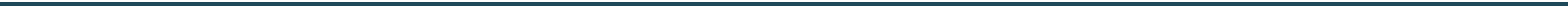

**KEY INTERLOCKS & PROCESS MANAGEMENT SYSTEMS**



‘Operating over 30 years, SFC is the global market leader in process safety and valve operations, offering innovative solutions that enhance efficiency and risk control’

01	Introduction
02	QL Valve Interlock
04	GL Valve Interlock
06	Closure Interlocks
08	Interlock Devices for Actuated (MOV) Valves
10	Key Storage & Management
12	ATL (Anti-Tamper Lock)
13	Security Products
14	Specials
17	IML - Intermediate Lock
18	SFC ‘COMM’ (Commissioning) Key
19	PSV Interlocking
21	Pig Trap Interlocking
24	Site Services
25	SFC Global Representation

Smith Flow Control Ltd  
6 Waterside Business Park  
Eastways Industrial Estate  
Witham Essex CM8 3YQ  
United Kingdom

Tel: +44 (0)1376 517901  
Fax: +44 (0)1376 518720

[sales@smithflowcontrol.com](mailto:sales@smithflowcontrol.com)  
[www.smithflowcontrol.com](http://www.smithflowcontrol.com)



# VALVE INTERLOCK SYSTEMS

Smith Flow Control (SFC) was established in 1985 to provide engineered safety solutions for hazardous operations in the oil & gas and chemical processing industries, although our products are now seen across a broad array of industries.

The industries in which we serve are no strangers to process and operational excellence, operating globally in some of the toughest and most challenging environments. Any accidents that occur have a high cost in terms of people, assets and the surrounding environment.

Maintaining safe operations is critical. Successful process safety implementation initiatives cannot only save companies millions in operating costs – it can also help augment business agility, drive innovation, and enhance regulator and public confidence. However, while good practice begins with inherently safe design, it is also hostage to the ‘human factor’

The range of process safety products offered by SFC, mitigate significant environmental and workplace risks: Mechanical valve interlocks remove the ‘human factor’ by reducing the risk of incidents and guiding the behavior of employees and contractors. Critical and dangerous processes happen only in a designated sequence, compelling compliance and negating shortcuts that could compromise a plant, process, people and the environment.

Typical applications include every form of valve (including motorised and instrument valves), switches, vessel closures, access guards, pressure and temperature sensing systems and rail/road/sea tanker loading systems for any other application requiring process control.

SFC’s solutions in hazardous process safety reduce the scope for operator error and ensure safe continuous plant operation.

## OUR COMMITMENT

Smith Flow Control remains committed to providing quality assured products, which are delivered on time and competitively priced. We remain committed to retaining the confidence of our clients by staying true to the ideals that have gained us the reputation we enjoy today.

# QL VALVE INTERLOCKS For lever operated valves

## QL VALVE INTERLOCK (QLT & QLR)

QL valve interlocks suit all types of lever-operated quarter-turn valves – including Ball, Butterfly and Plug valves.

Installing the interlock on the host valve is a simple procedure and requires no modification or hot-work to the host equipment as the anchor and adaptors are custom-machined to suit the valve.

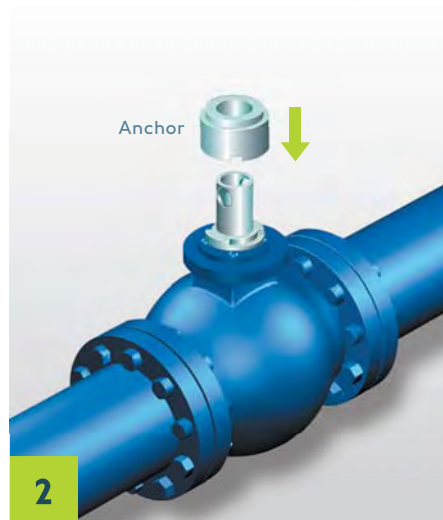
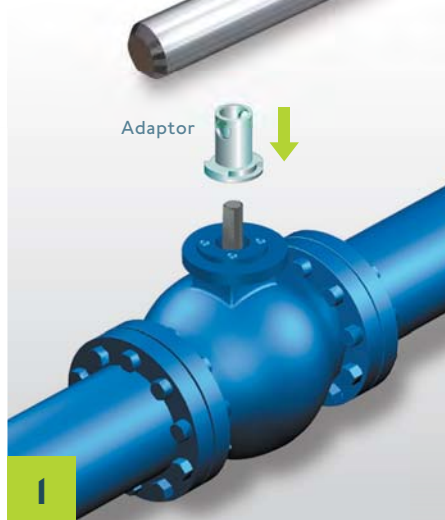
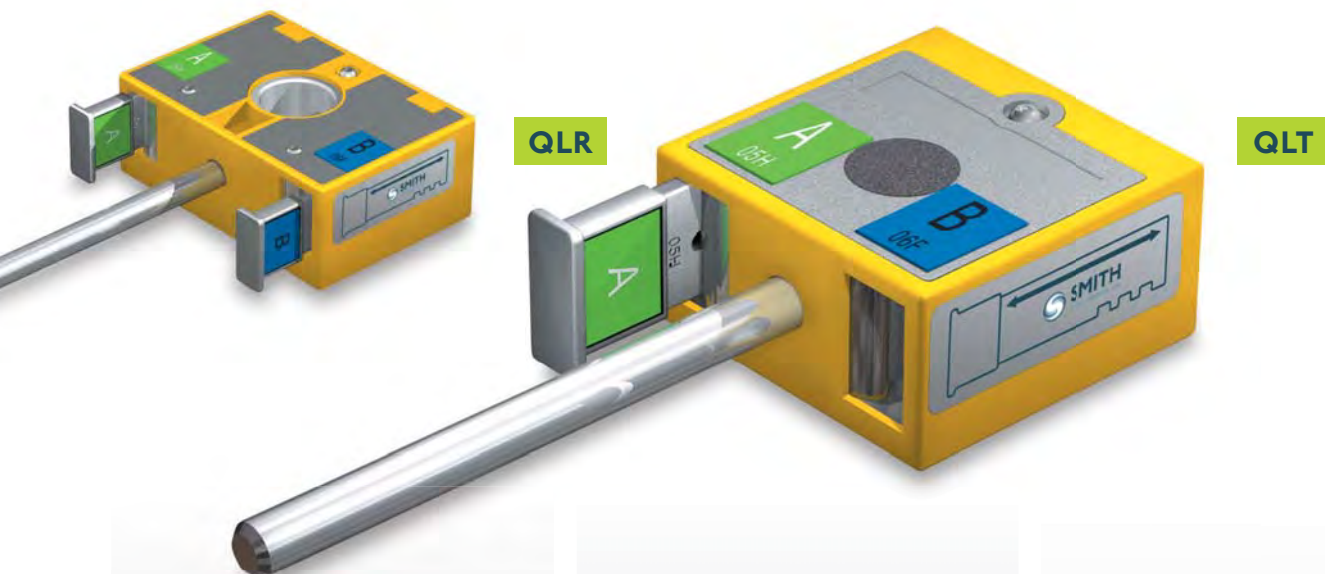

After removing the existing Lever the QL is assembled as follows:

- 1 Install lock adaptor.
- 2 Install anchor.
- 3 Fit SFC nut.
- 4 Assemble QL lock, secure lever and tighten screw.

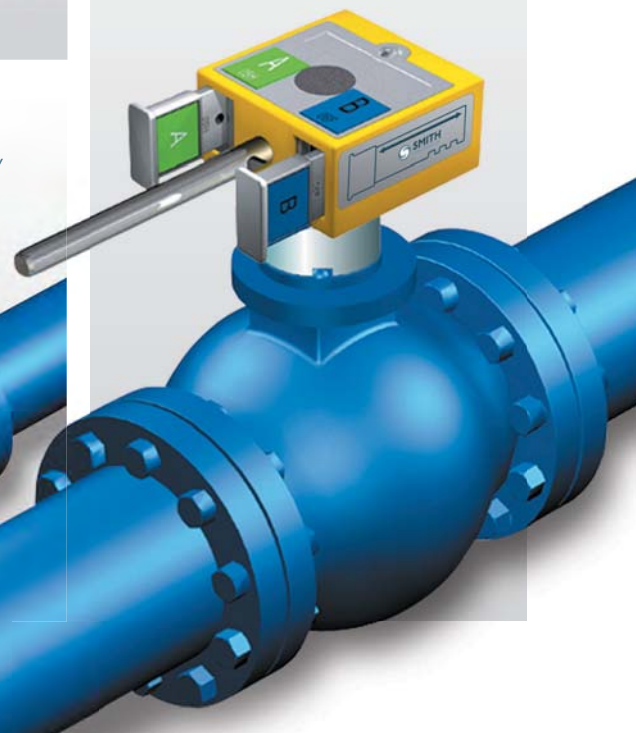
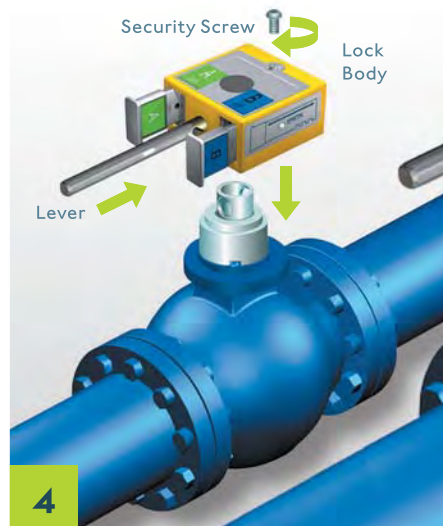

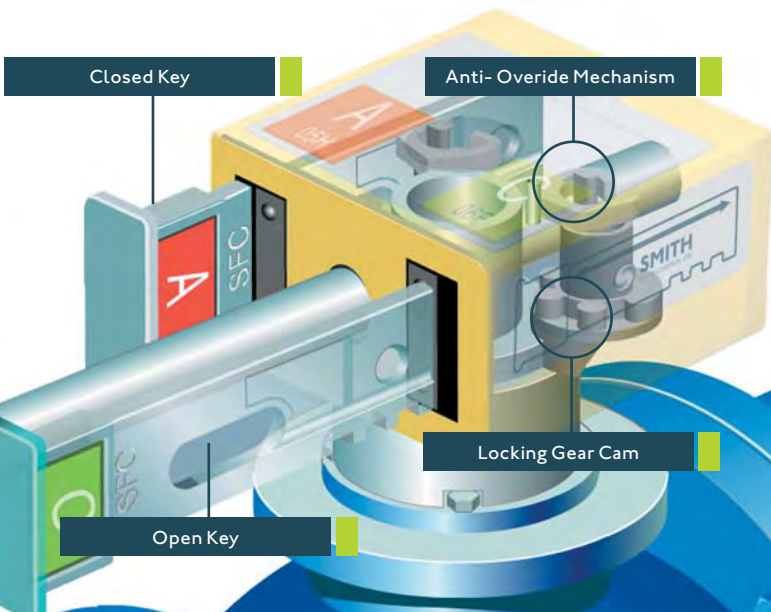
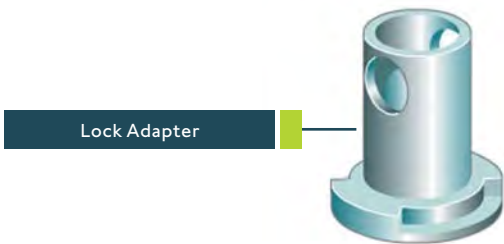
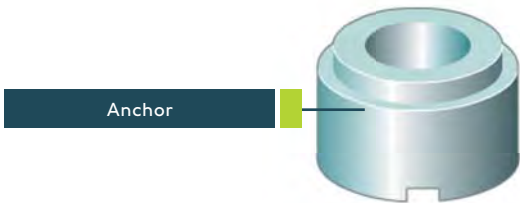
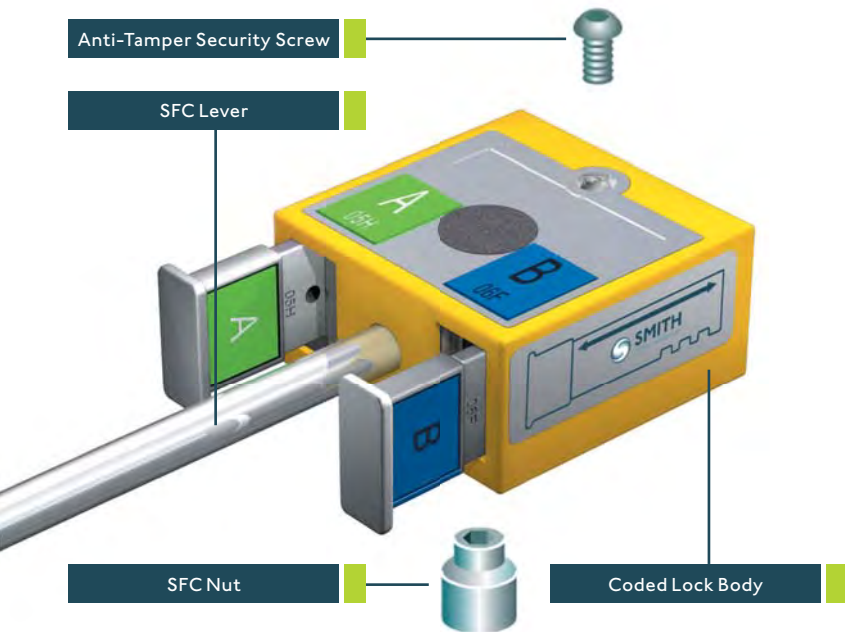

## PRODUCT FEATURES

- 316 Stainless steel.
- Linear 'coded-card' key design.
- Robust construction.
- Proven reliability in all climates.
- Single or double key versions.

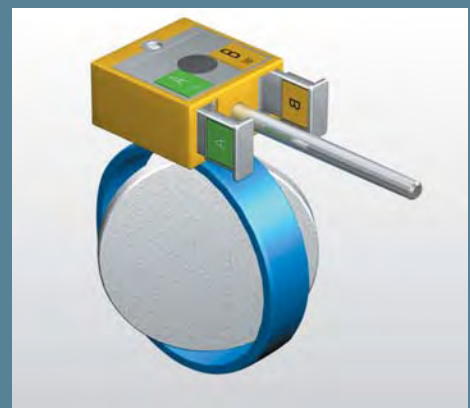
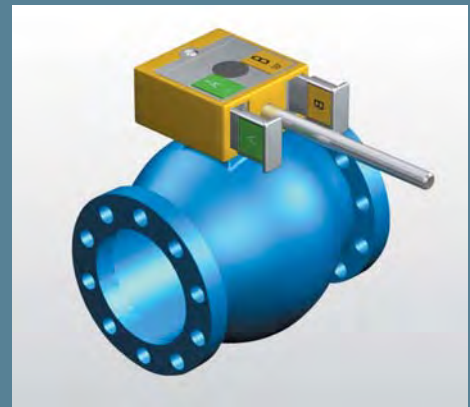

- No modification to host valve.
- Suitable for any valve type/model.
- Can be installed on 'live' plant.



# GL VALVE INTERLOCKS For handwheel operated valves

## GLM & GLS VALVE INTERLOCKS

GL valve interlocks suit all types of handwheel operated valves - including Gate, Globe and Gear-operated valves.

Installing the interlock on the host valve is simple. Requiring no modification or hot-work to the host equipment, the anchor and adaptors are custom machined items. Universal Adaptors (UAS) may be supplied when precise valve topworks data is not available.

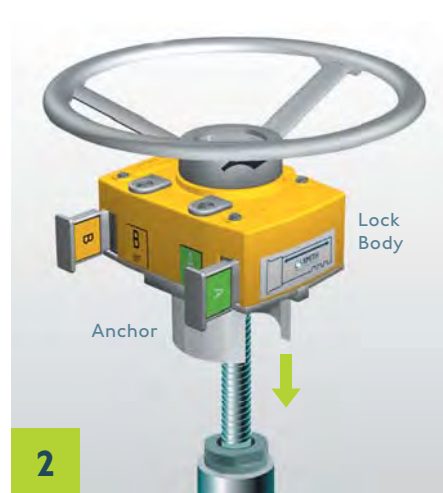
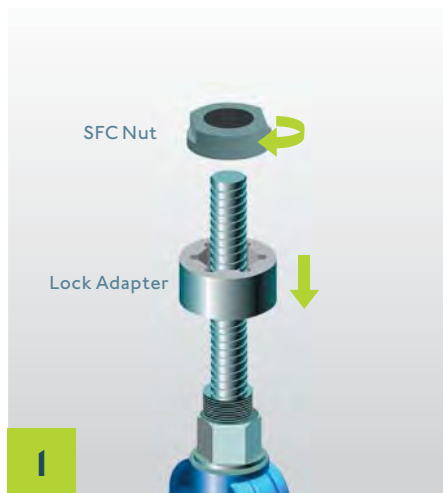

After removing the existing handwheel the GL is assembled as follows:

- 1 Mount lock adaptor and fix SFC nut.
- 2 Locate body to adaptor.
- 3 Tighten fixing screws (x3).
- 4 Tighten setting screws to set "Open" and "Closed" key release positions.



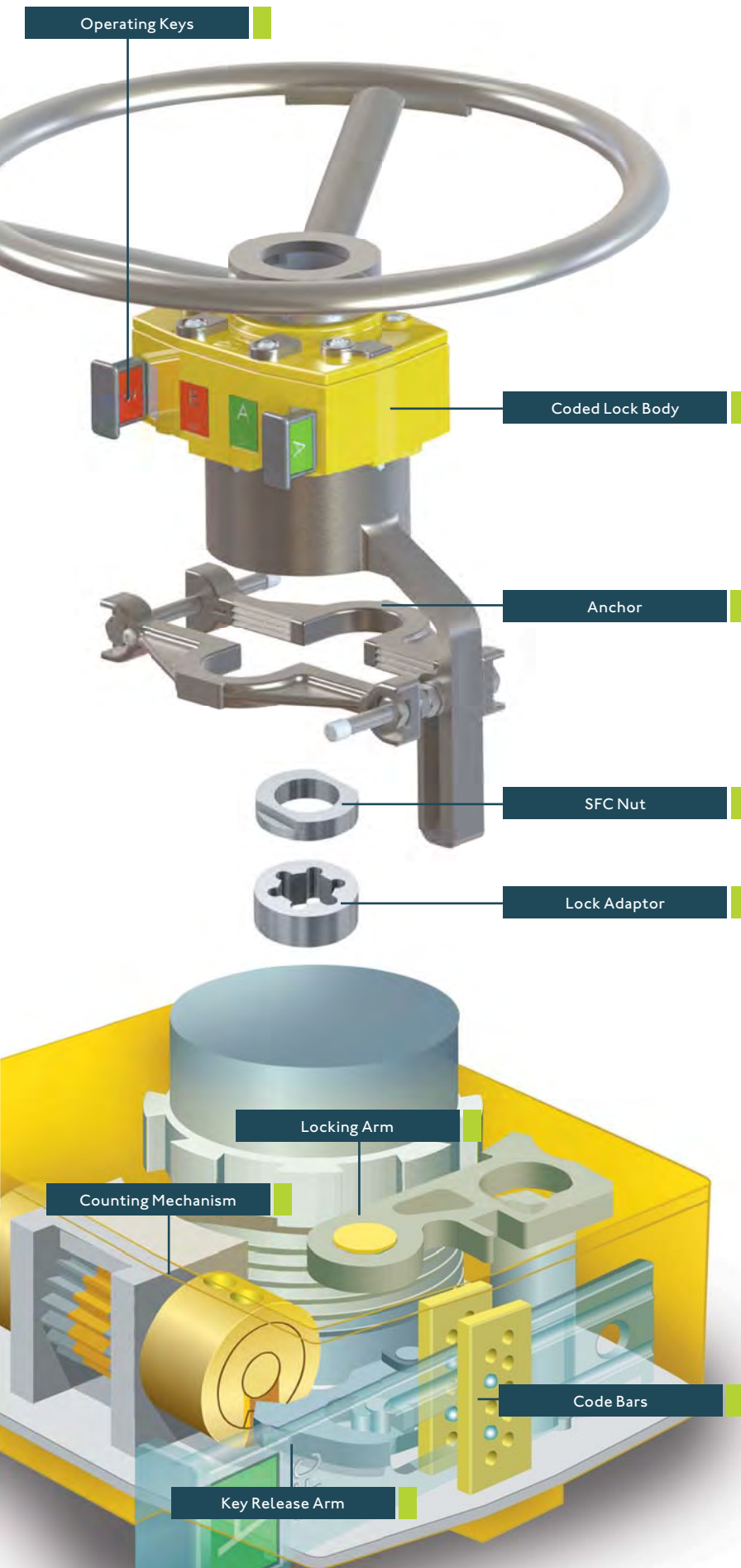

## PRODUCT FEATURES

- 316 Stainless steel.
- Linear 'coded-card' key design.
- Robust construction.
- Proven reliability in all climates.
- Single or double key versions.
- Suitable for all handwheel operated applications.



- No modifications to host valve.
- Suitable for any valve type/model.
- Can be installed on 'live' plant.





Ensure total isolation, venting and draining **BEFORE** opening vessel closure.

## INTRODUCTION

Access into pressure vessels is a potentially hazardous exercise. Residual pressure, volumes of residual liquids or gases all can be harmful - typical examples of these potential hazards include pig traps, slug catchers and filter housings.

Locking the vessel closure in the closed position ensures access into the vessel can be achieved only under controlled safe conditions. The operating key is held in a secure place - e.g. Control Room or Supervisor's office or is retained (trapped) in some other related interlocked item of equipment.

Most international vessel design codes as a minimum require vessel closures to be interlocked with venting and draining functions - this interlocking arrangement can be extended to incorporate all other vessel functions (e.g. draining, purging or flushing).



Locking Arm Engaged



Locking Arm Released

## Prevent loss of containment of explosive or toxic product.

Any type of closure can be fitted with the 'DL3' interlock, regardless of their method of operation. Design details can be provided on request.

- Two-Piece Lock.
- When the two lock halves are separated, the interlock key remains trapped in the DL3 door lock.



### PRODUCT DETAILS

The SFC 'DL3' interlock is adaptable to all types of vessel/access closures and is very simple to use in pig trap applications especially where the closure incorporates a bleed device.

The 'DL3' interlock will be designed to interface with the bleed function to ensure the bleed screw cannot be removed until the interlock permit key has been inserted to unlock the 'DL3' assembly. This key is usually obtained after opening and locking of the vent valve.

When the 'DL3' is incorporated into vessel access safety procedures, total equipment and personnel safety is assured.



# INTERLOCK DEVICES FOR ACTUATED (MOV) VALVES

## ACTUATED VALVES

The most common requirement for key interlocking of power actuated-valves occurs in Pig Launcher/ Receiver systems, Scraper Traps and Sand Filter systems etc. where power actuated valves need to be interlocked with manually-operated valves and the vessel closure.

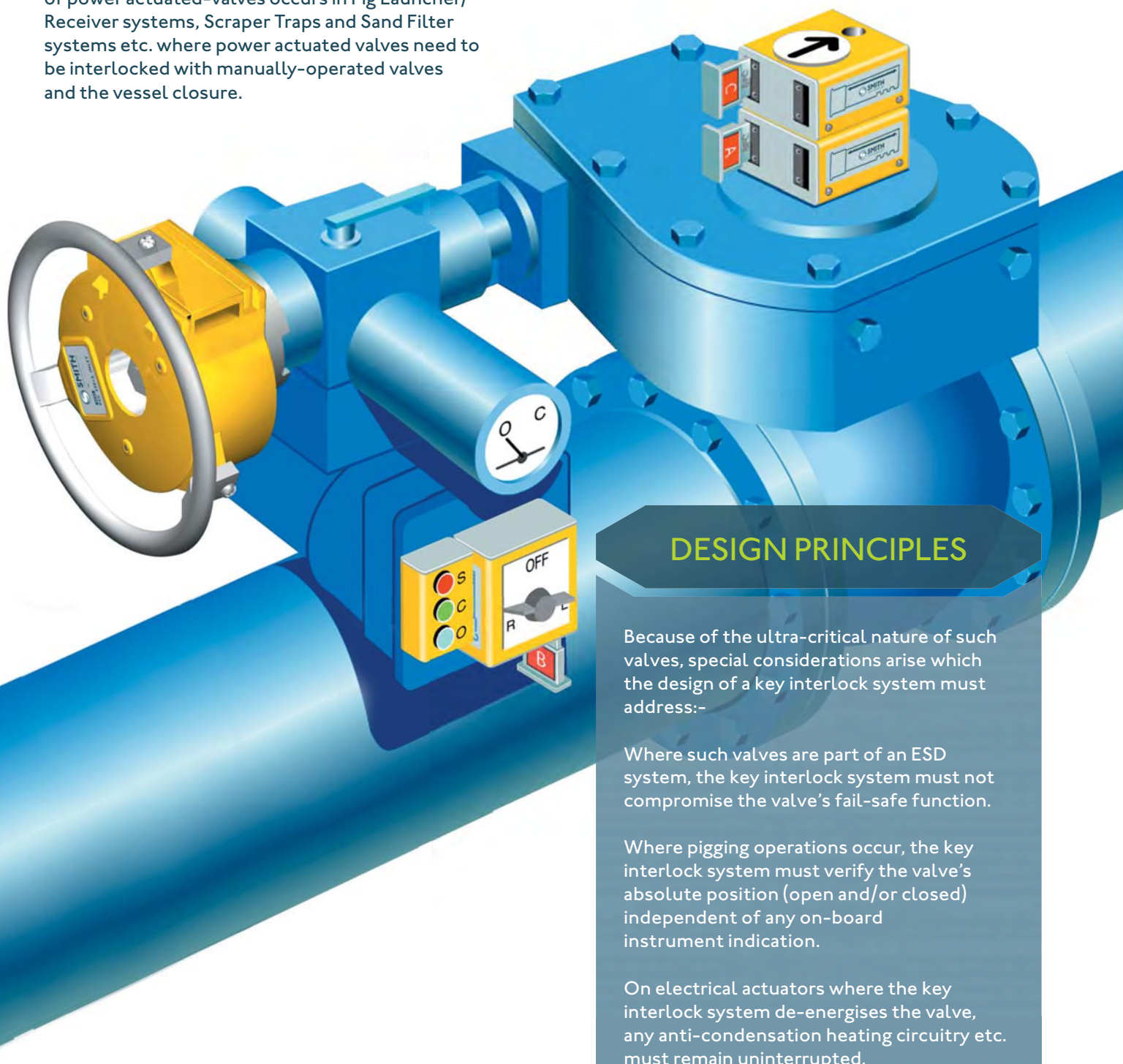

### DESIGN PRINCIPLES

Because of the ultra-critical nature of such valves, special considerations arise which the design of a key interlock system must address:-

Where such valves are part of an ESD system, the key interlock system must not compromise the valve's fail-safe function.

Where pigging operations occur, the key interlock system must verify the valve's absolute position (open and/or closed) independent of any on-board instrument indication.

On electrical actuators where the key interlock system de-energises the valve, any anti-condensation heating circuitry etc. must remain uninterrupted.

Where actuators are equipped with a manual override facility, the key interlock system must permit operation of the valve in both modes (or in a combination of both modes - e.g. in the event of a power failure) while maintaining the integrity of the key sequence at all times.

## EQUIPMENT STATUS:- VALVE OPEN

'SLU' Switch Unit Locked in 'REMOTE'.  
'HWL' Handwheel Drive Locked 'OFF'.  
'A' Key in Control Room.

TO CLOSE VALVE:

- 1 'A' Key into 'AKE' positional indicator unit.  
'B' Key is removed from 'AKE' - 'A' Key trapped.
- 2 'B' Key into 'SLU' Switch Unit to unlock.  
'SLU' Unit switched to 'LOCAL' ('B' & 'C' Keys trapped).  
Operate button to close valve.
- 3 'SLU' Unit now switched to 'OFF' - 'C' Key is removed.  
'SLU' Unit locked in 'OFF' position trapping 'B' Key.
- 4 'C' Key into 'AKE' Unit - remove 'D' Key trapping  
'C' Key. 'D' Key is then directed towards continuation  
of the procedure.

NB The 'D' Key will not release unless the valve has completed its full stroke to the CLOSED position.

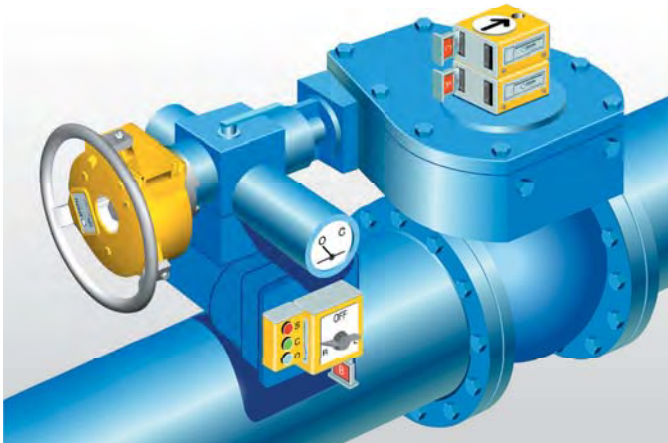

## EQUIPMENT STATUS:- VALVE CLOSED

'SLU' Switch Unit Locked 'OFF'.  
'HWL' Handwheel Drive Locked 'OFF'.  
'D' Key in Control Room.

TO OPEN VALVE:

- 1 'D' Key into 'AKE' positional indicator unit.  
'C' Key is removed from 'AKE' - 'D' Key trapped.
- 2 'C' Key into 'SLU' Switch Unit to unlock.  
'SLU' Unit switched to 'LOCAL' ('B' & 'C' Keys trapped).  
Operate button to open valve.
- 3 'SLU' Unit now switched to 'REMOTE' - 'B' Key is removed.  
'SLU' Unit locked in 'REMOTE' position trapping 'C' Key.
- 4 'B' Key into 'AKE' Unit - remove 'A' Key trapping  
'B' Key. 'A' Key is then directed towards continuation  
of the procedure.

NB The 'A' Key will not release unless the valve has completed its full stroke to the OPEN position.

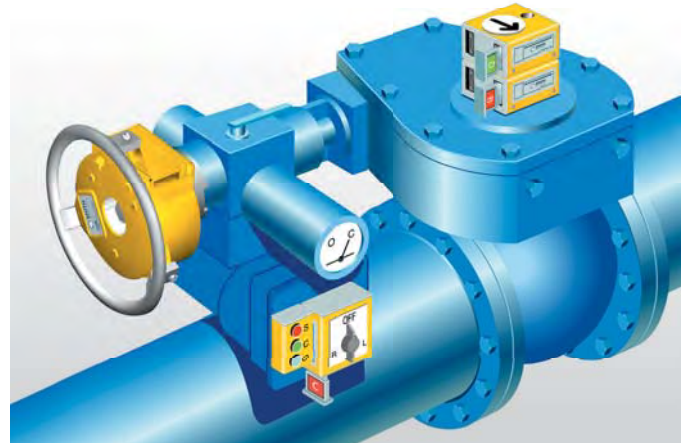

## HYDRAULIC & PNEUMATIC ACTUATORS

A range of comparable designs are also available for spring return and non-return hydraulic actuators and for spring-return pneumatic actuators.

SFC's range of special process products also includes needle valve locks, temperature and pressure sensing locks and a range of signalling options to meet most process operating requirements.

## ACTUATORS FOR GATE VALVES

These same key sequencing principles can be applied effectively to the management of motorised gate valves.

## POWER FAILURE MODE

In the event of a power failure at anytime during either of the above procedures, it is essential the integrity of the key sequence is maintained if the valve is operated manually.

This is achieved simply by locking the 'SLU' Unit in the 'OFF' position thereby releasing the 'C' Key. (Even if power is restored, with the 'C' Key free, the valve/actuator will remain disabled).

The 'C' Key is inserted into the freewheeling 'HWL' handwheel assembly - this lock functions on a 'declutching' principle. With the 'C' Key trapped, the 'HWL' drive mechanism may be engaged thereby enabling the valve to be operated.

While the 'C' Key can be removed from the 'HWL' assembly at any time, it has to be exchanged through the 'AKE' unit to secure the continuation key (e.g. the 'A' or 'D' Keys in the above examples) - these keys will only release provided the valve has completed its full stroke.



# KEY STORAGE & MANAGEMENT

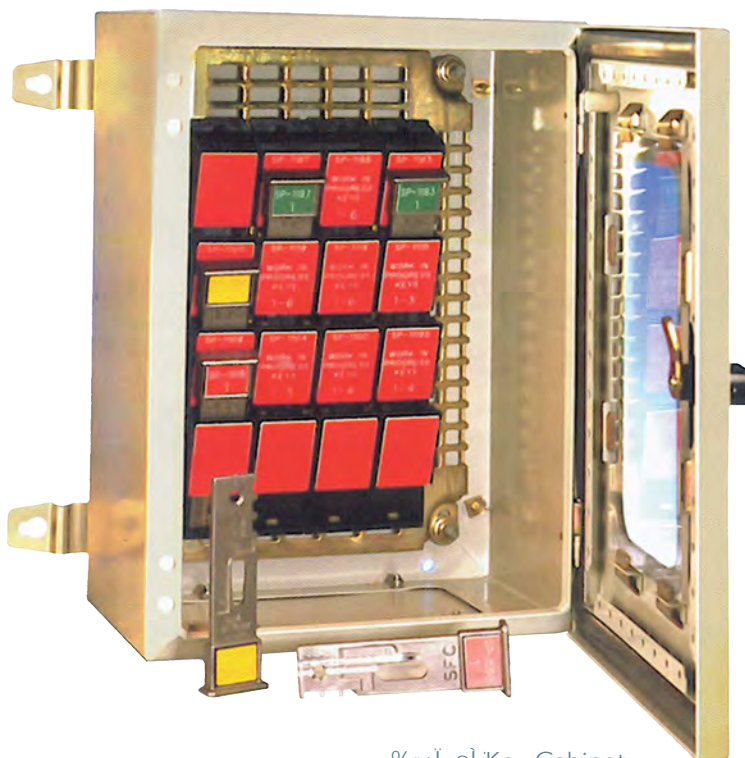

Key Cabinet

SFC Process Management Systems provide effective protection to clients' investments in plant and equipment as well as improving employee safety and reducing the risk of damage to the environment.

## SFC 'VISUAL ALERT' KEY MANAGEMENT SYSTEMS

An effective and efficient key management system provides a continuous and reliable indication of the status of all interlocked process systems.

SFC's 'Visual Alert' Key Cabinets provide an effective and infallible management control system against unauthorized or inadvertent operation of interlocked valves or associated process equipment by keeping the coded keys, which initiate the operation of critical valves, under secure supervisory control. For storage, ease of access and issue, SFC's key cabinets, provide all that is required.

Typically, a key cabinet will be found in a secure place; e.g. a control room whereby initiating keys are issued by the Shift Supervisor, Offshore Installation Manager or another person in authority. Cabinets vary in size and can accommodate from 1 – 280 system initiating (or spare) keys.

**Holster** - The standard holster design provides up to 260 allocated key positions.

**Horizontal** - This pin coded cabinet offers up to 280 unique key positions with the option to incorporate a microswitch to signal key movements.

**SmartKey+** - SFC's latest key cabinet design, accommodating up to 75 system positions and incorporating RFID (radio-frequency identification) technology.

### DESIGN FEATURES AND BENEFITS

- Carbon or Stainless Steel construction available.
- 'Glazed' door provides key status without the need to open/un-lock.
- Ingress protection from IP55 to IP66.
- Lockable doors.
- Wall brackets provided.
- Complete key status awareness.
- Holster, Horizontal and SmartKey+` I W\$S×k. ×k\$Ĵ Ĩâl †W\$¼

# KEY CABINETS

Each interlocked system has an allocated engraved tag location within the key cabinet. During periods of normal operations, all interlock system 'permit' (initiating) keys are visually displayed within the cabinet in allocated locations. Each key cabinet tag is engraved with the relevant piping package data – this same data is also replicated on each system key.

When the key is removed, a 'Visual Alert' tag is revealed providing details of the key which has been issued, its designated location, and the words 'WORK IN PROGRESS'. Control Room staff have clear and easy indication of work status at any time. Key cabinets can also accommodate mimic diagrams as specified by the customer.



Horizontal Key Cabinet

## SMARTKEY+



SmartKey+ Cabinet

**SmartKey+ provides a unique solution to key management, combining innovative software and smart technologies.**

SmartKey+ provides all the features of SFC's Visual Alert Key Cabinet, along with the ability to record movements of keys in real-time, providing complete accuracy.

This style of cabinet incorporates RFID recognition, enabling a key to be tracked with complete confidence and provides operator and control room personnel with information on interlocked processes and their status.

Full transaction history is available, revealing details of key insertion/removal. The unit is designed to support remote web interface, without any specific licence. SmartKey+ has enhanced levels of system security, the system automatically records when a key is used and by whom on a central database. The cabinet is configured around a central control panel capable of running a system with 75 keys and is comprised of modular sections, each containing 15 key positions, which can be increased incrementally.



# ATL (ANTI-TAMPER LOCK)



## INTRODUCTION

Many valves on site require a simple to use locking device to prevent accidental or unauthorised operation.

## CONSTRUCTION

ATL is available in two sizes covering all valve sizes and is available in 316 Stainless Steel. For remote unmonitored or higher security risk areas, a carbon steel, case-hardened option is available, which will withstand the toughest forms of vandalism.

## CODING

The units can be uniquely coded or coded alike, dependant on operational conditions/ requirements.

## OPERATION

With the unit fitted to the valve, the standard SFC tamper-proof coded card key can be inserted allowing valve operation. Depending on operational requirements, the valve can be operated to any position, once the key has been removed, the unit free wheels - preventing valve operation.

## ORDERING

The units are available 'off the shelf' allowing customers to undertake the simple machining operation for fitting, thus reducing order times and offering an instant security/safety solution.

## PRODUCT DETAILS

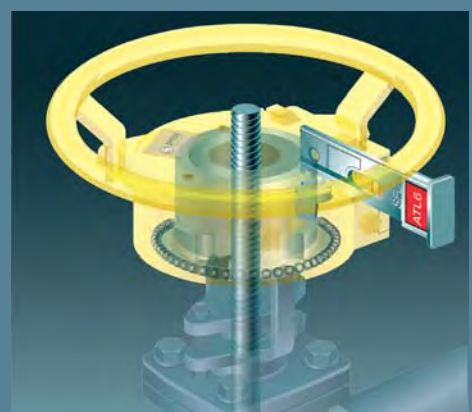

Many valves on site require a simple to use locking device to prevent accidental or unauthorised operation.

The ATL has been developed to fit directly to valves in place of the normal handwheel or operating lever, with little machining which can easily be undertaken by the customer.

# SECURITY PRODUCTS

Where security lock-off devices are required to provide mechanical locking of manual equipment, SFC offer a full complement of security and commissioning tools. If sequential control is unnecessary but a secure lock is required, the SFC range of security products can provide the solution you need.

## EXPANDED CHAINLOK



The Chainlok is a unique device which combines the best features of padlocks and interlocks.

A durable body and chain made from 316 Stainless Steel makes it suitable for use in the most hostile environments. Chainlok comes with 0.5m chain as standard (longer lengths available on request). Flag style 'Colour Aware Key' enables incorporation into interlock (key exchange) systems.

**Operating condition;**

Key Trapped - Chain Free  
Key Free - Chain Locked

Flip caps prevent ingress of foreign matter when key is removed.

## CAR SEAL



For 'one-time-only' securing of manual operators, including securing of manual valves, switches and enclosures. A simple 'break-away' screw secures the seal in place. Removal can only be achieved by cutting the seal cable.

Two body and cable sizes are available, along with varying lengths of cable. Cable breaking strains are available to 1750kg.

Re-usable car seals are also available.



Ideal for use in commissioning procedures.



# SPECIALS

The range of process applications to which SFC interlocks can be applied is unlimited. As clients begin to understand the immense operational capabilities of SFC interlock systems, they often request unique solutions to specific problems.

In this section we present some examples of 'specials' we have developed to meet clients' specific operating safety requirements.

SFC are always pleased to receive a challenge to provide unique solutions to clients' individual or special problems.

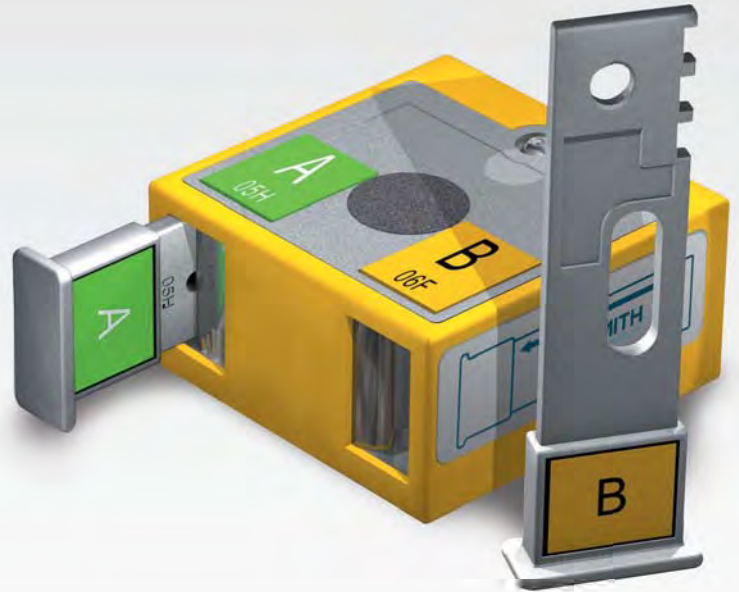

## SEQUENCE CONTROL UNIT



### CUSTOMER PROBLEM

To permit complex variations in operating sequences on launcher/receiver systems.

### SFC SOLUTION

The simplest interlock systems will normally feature a 'linear sequence'. This is where the outward 'journey' (operating steps) are mirrored by the return journey. However, from time to time, non-linear sequences are necessary. A typical example of a non-linear sequence is a pig trap procedure where double block and bleed valves control complex nitrogen purging, pressure equalisation, venting and draining.

The sequence control unit is a mechanical key issuing/control device. It is normally placed locally to the valve system. It differs from a key exchange unit in that, upon inserting a permit key, a selector knob is rotated to a fixed position before the next key is issued.

## SFC DUST PLUG

---

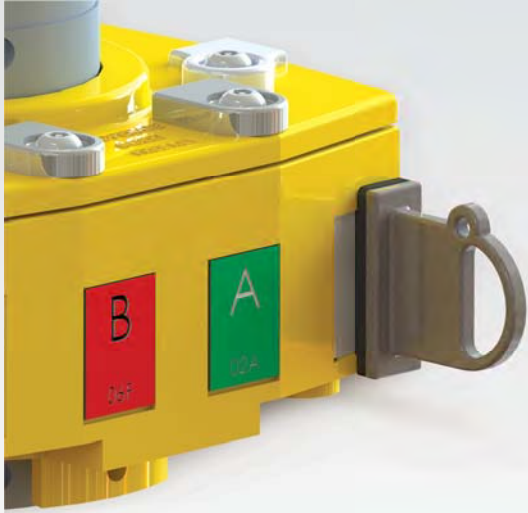

Removal of a key from the assembly increases the scope for the ingress of dust and dirt through the key entry aperture which can contaminate the inner workings of the lock mechanism - leading ultimately to possible seizure and malfunction.

The SFC 'Dust Plug' is a simple and highly effective solution to prevent this happening.

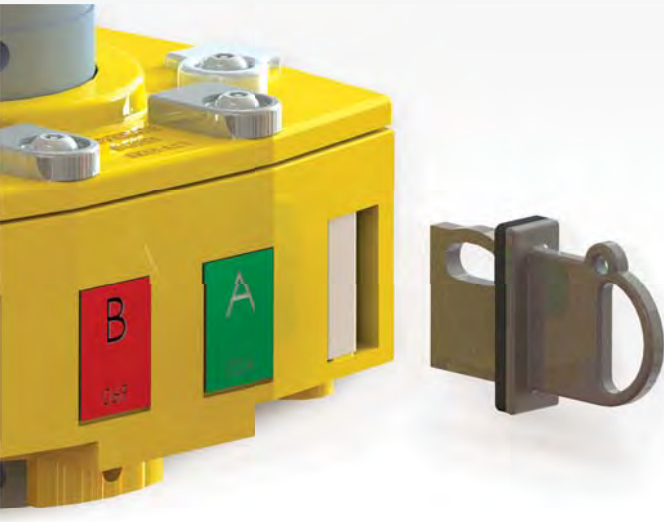

**Key operated locking devices invariably feature a key entry aperture to facilitate locking and unlocking of the assembly.**

Made from HDPE and fitted with a soft sealing aperture gasket, the SFC 'Dust Plug' is inserted by the operator to seal the key entry aperture immediately after he has removed one or the other of the operating keys coded keys from the lock assembly.

The SFC 'Dust Plug' is a tight-fitting component that positively seals the key entry aperture and will not become dislodged through vibration once properly fixed in position by the operator as he completes his scheduled work procedures.



## EXPLOSION PROOF INTERLOCKED SWITCH



### CUSTOMER PROBLEM

To mechanically interlock an electrically operated device, within a hazardous environment - ATEX certified.

### SFC SOLUTION

Where mechanical (interlocked) control of powered equipment is required in a hazardous area, the SFC switch lock provides the perfect solution.

In this illustration our 'QL' quarter turn interlock is fitted to the switch mechanism of an II 2 G D hazardous area control switch.

A single or dual key configuration can be supplied to lock in the 'ON', 'OFF' or both positions.

Solenoid key release units are available. These are commonly used around Pig Traps to receive a 'low pressure' signal to indicate it is safe to proceed to open the door.

## QL WITH PROXIMITY SWITCH



### CUSTOMER PROBLEM

Additional signalling required.

### SFC SOLUTION

ATEX certified proximity switches can be incorporated into all SFC interlocks to provide signals to indicate:

- A Key entry or removal
- B Valve open or closed, indicated by the removal of the key and locked in that position

'Off the shelf' proximity & microswitches are integrated with our interlocks units.

# IML - INTERMEDIATE LOCK

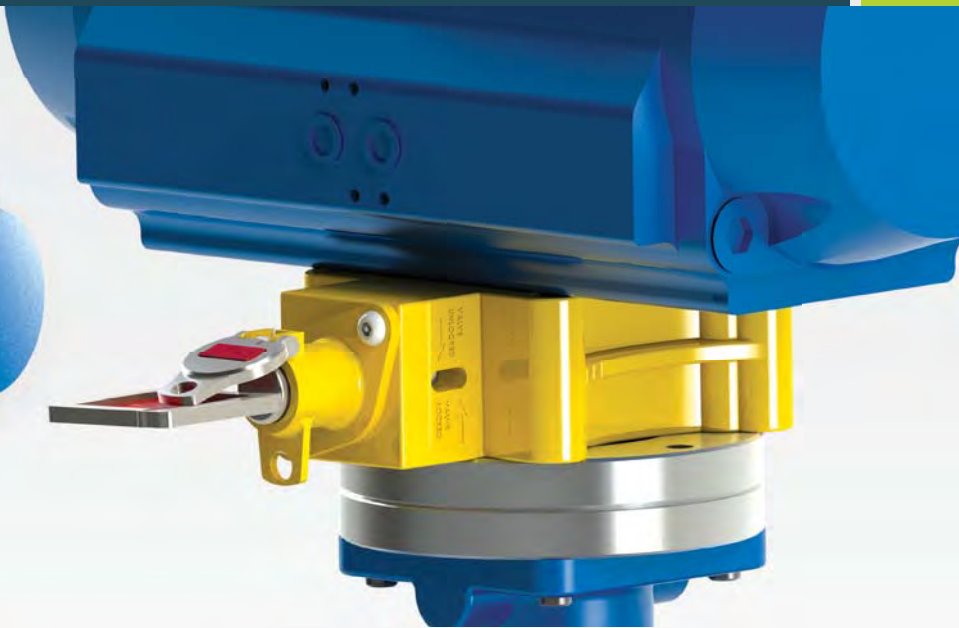

The ISO pattern 'IML' intermediate lock that enables full mechanical control of any ISO pattern actuator.

Actuated valves in process operations are normally maintained in an energised state and may otherwise be part of a DCS managed system. During normal operations these valves will respond to process commands in a pre-determined manner.

However, during periods of planned maintenance the command architecture managing these valves may need to be suspended to facilitate prescribed work tasks. In these circumstances it may be essential to ensure that such valves are set to their failsafe position and are disabled both remotely and locally so that work may proceed safely.

The SFC 'IML' lock is a mechanical device that interfaces between the actuator and its host valve. It uses an operating key facility to lock the actuator in the desired open or closed position so that the valve is prevented from turning under any circumstances.

This key may be a part of an additional designed-in feature whereby the power source that energises the valve can be interlocked with the IML unit itself to provide a total failsafe solution by ensuring the power source and the actuator are mechanically interlocked and all functions are disabled.

With all ISO 5211 patterns covered from F05 to F16, the six models of the IML will interface immediately to any ISO pattern actuator and replaces the requirement for a valve mounting kit.

The maximum flange torque for each hole pattern in line with ISO 5211 is :

F05	125Nm
F07	250Nm
F10	500Nm
F12	1000Nm
F14	2000Nm
F16	4000Nm

The 'IML' is available in two compact mechanical configurations :

- A key-operated system managed from the Control Room as part of a structured 'Permit to Work' ('PtW') management system.
- A simple stand alone lock-out system which satisfies OSHA Standard 1910.47 - 'Control of Hazardous Energy'



# SFC 'COMM' (COMMISSIONING) KEY

Installation of key interlock systems is usually one of the final tasks to be performed before final commissioning and handover of a project to the client.

However, interlocks can impede final commissioning procedures by preventing valve settings necessary to create the process conditions for commissioning (hydro-testing) of piping systems.

One solution is to defer actual fitting of the key interlock systems until all mechanical completion tasks are accomplished.

This arrangement is seldom satisfactory – particularly as there may be a number of different contractors involved in the final commissioning programme.

Commissioning of mechanical key interlock systems ideally must be undertaken and completed by one responsible party – particularly with regard to management of the control keys.

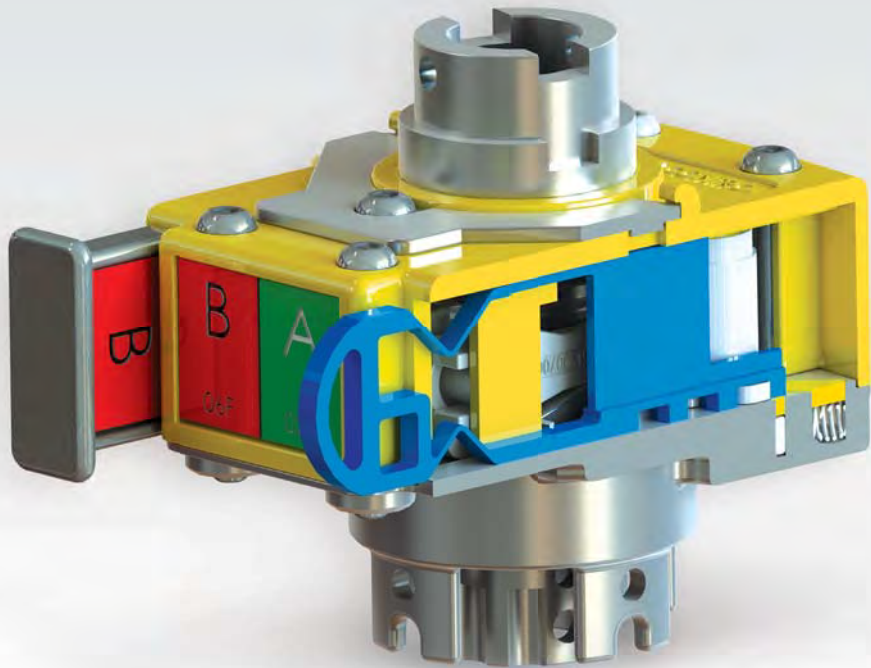

## CONSTRUCTION

The SFC 'ComKey' provides a simple effective solution to this problem and enables all parties to complete their respective work responsibilities without compromising the designed 'logic' of the installed interlocks and without the interlocks impeding final completion tasks.

SFC Interlocks are supplied as standard with one key trapped and one key free. However, for situations where any of the above issues are relevant, SFC interlocks can be supplied with factory-fitted 'ComKey' that permit random operation of the installed interlock irrespective of the coded logic of the interlock system.

## CODING

The SFC 'ComKey' is a 'one-time-only' design facility feature – once the key is removed after all testing/commissioning tasks are completed it cannot be re-used – the installed interlock will only then accept its dedicated coded key for normal operations.

The SFC 'ComKey' eliminates the necessity for commissioning master keys, saves time and simplifies site logistics related to the distribution and control of system operating keys.

**'ComKey' – another innovative simple safety solution from SFC.**

## PRODUCT DETAILS

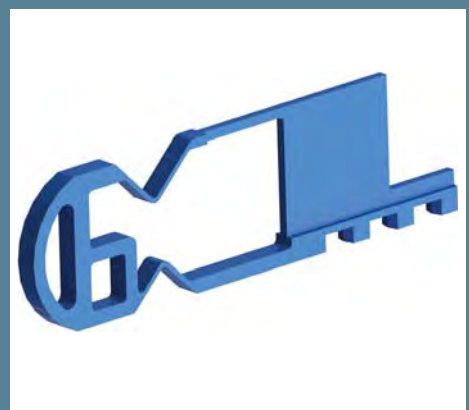

The SFC 'ComKey' is available to suit all type of Smith Flow Control key operated products.

All 'ComKey' systems must be specified at the time of order placement, as each lock is assembled with the system pre-installed.



## PSV SYSTEMS

---

**Whether onshore or offshore, maintenance procedures to Safety Relief Systems on live plant cause concern in ensuring that an open path to relief is maintained at all times during the work exercise.**

Most modern piping arrangements include spare relief capacity enabling continuous production while maintenance procedures are conducted on live plant eliminating the requirement to isolate and shut down the process.

Twin or multiple safety relief valve systems are usually fitted with isolation block valves upstream and downstream of each safety relief valve – it is essential to ensure that the block valves isolating the spare relief valve are opened BEFORE the block valves of the work piece relief valve are closed.

This issue is a more acute problem if the respective relief valves and isolating block valves are distant or out of sight of each other.

Various API and ASME codes recognise this hazard and recommend the use of interlocks to eliminate this possibility. API RP 520 (Pressure Relieving Systems for Refinery Services – Part II Section 4– Isolation Valve Requirements) and API RP 14E (Design and Installation of Offshore Production Platform Piping Systems – Para 5.8b [2] – Relief Device Piping) specifically recommend interlocks in this situation to ensure that (over) pressure protection of the vessel is not compromised. Otherwise, many leading OpCos have their own written engineering design standards that specify similar safety design requirements.

Fitting a valve interlock to the upstream and downstream isolating valves on each safety relief valve (PSV) will ensure these recommendations are implemented.

An initiating key, issued from a secure location (Control Room) commences the PSV changeover. Follow the step-by-step procedures in the diagram.

# PSV INTERLOCKS

## 4 VALVE PSV INTERLOCK SYSTEM

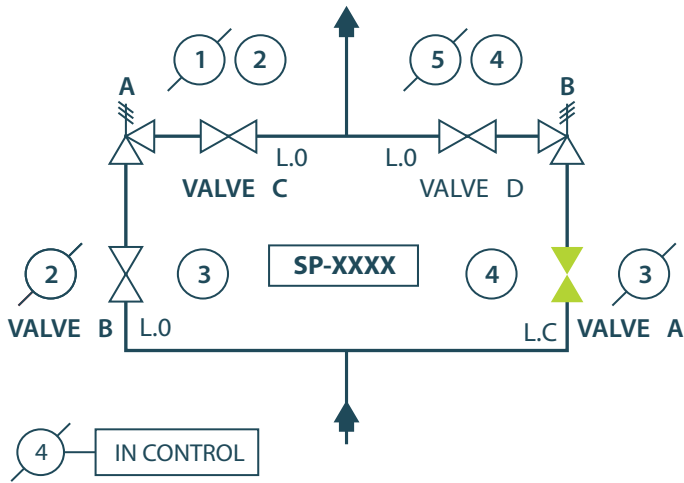

KEY IN CONTROL ROOM	VALVE POSITION			
	A	B	C	D
1	OPEN	CLOSED	CLOSED	OPEN
2	OPEN	CLOSED	OPEN	OPEN
3	OPEN	OPEN	OPEN	OPEN
4	CLOSED	OPEN	OPEN	OPEN
5	CLOSED	OPEN	OPEN	CLOSED

LEGEND			
VALVE LOCKED OPEN		KEY FREE	
VALVE LOCKED CLOSED		KEY TRAPPED	

### Front and Rear view of Key(s) - Example of Key Marking and Colours

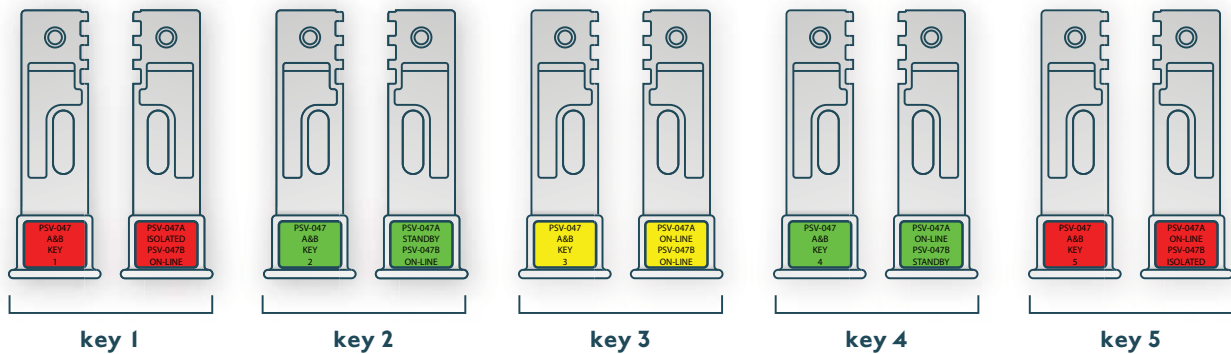

### Sequence of Operation: (Starting from Normal Operating Condition)

#### 1 Change-Over Sequence from PSV A Operational to PSV B Operational

- Obtain Key '4' from Control.
- Insert Key '4' into Valve A. Open Valve A. and lock open by removing Key '3'.
- Insert Key '3' into Valve B. Close Valve B. and lock closed by removing key '2'.
- Return key '2' to Control.  
(Change -Over complete)

#### 2 Complete Isolation of PSV A

- Obtain Key '4' from control.
- Insert key '4' into Valve A. Open valve A. and lock open by removing key '3'.
- Insert '3' into Valve B. Close Valve B. and lock closed by removing key '2'.
- Insert Key '2' into Valve C. Close Valve C. and lock closed by removing key '1'.
- Return Key '1' to Control.  
(Isolation of PSV A. complete)

#### 3 Complete Isolation of PSV B

- Obtain Key '4' from Control.
- Insert key '4' into Valve D. Close Valve D. and lock closed by removing Key '5'.
- Return Key '5' to Control.  
(Isolation of PSV B. complete)



# APPLICATIONS PIG Trap Interlocking

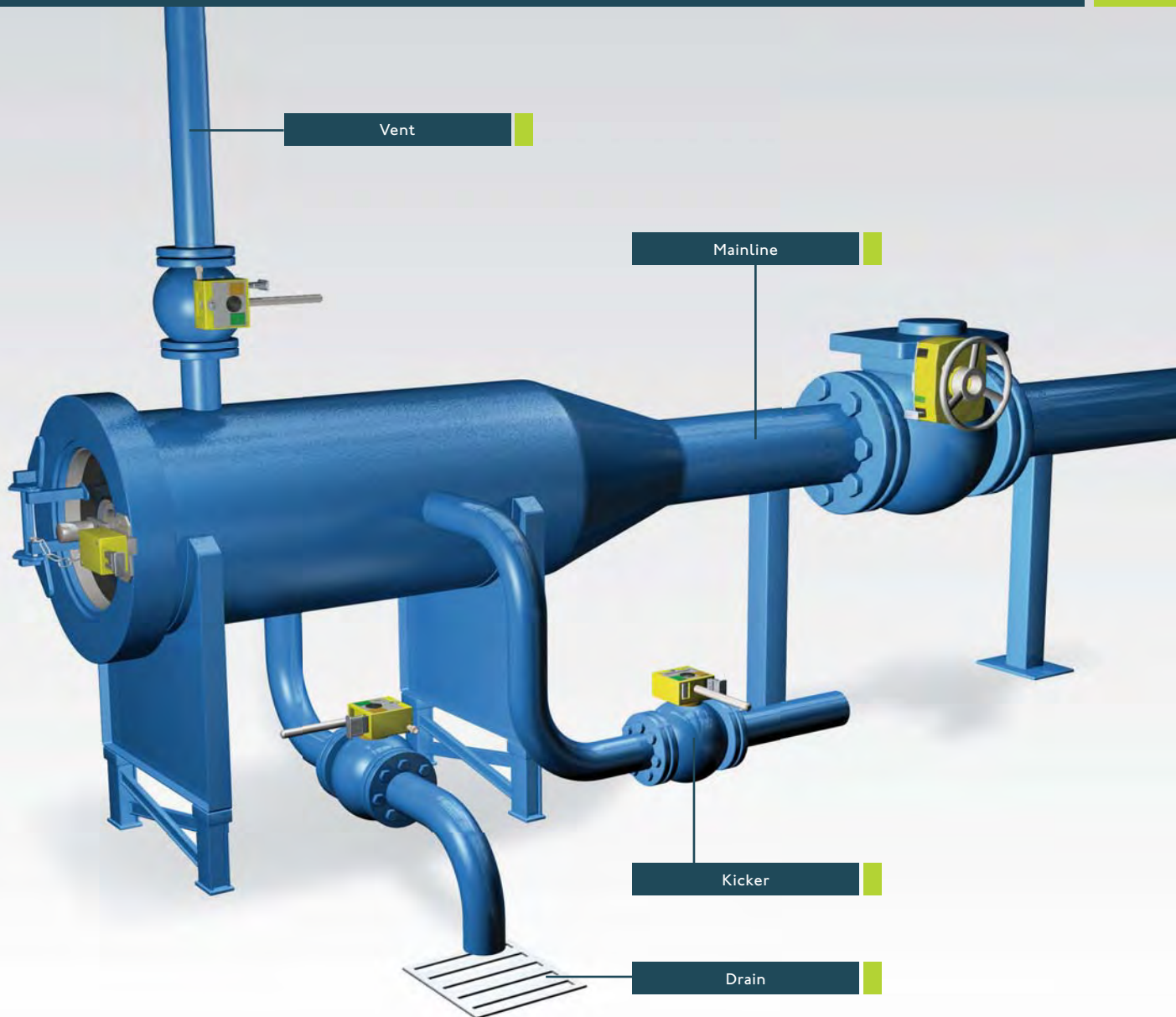

## PIG TRAPS

**Pig trap accidents involving operator intervention can be prevented by SFC coded-card key interlock systems.**

ASME and API codes recognise pig trap hazards – especially in relation to the risk of opening closures while the vessel remains under pressure. The Pipelines Safety Regulations 1996 enacted into UK law in April 1996 requires operators of pipelines to provide safety systems that ensure persons are protected from risk to their health and safety – again describing the hazard of opening pig trap vessels under pressure.

Many major OpCos also have their own written design standards specifying safety interlocks as an essential feature in their pig trap designs.

SFC interlocks can be specified to ensure the minimum safety arrangement of interlocking the vessel vent valve with the pig trap closure. This arrangement ensures (to the exclusion of all other methods) the vessel VENT valve is OPEN before any attempt can be made to open the closure.

With interlocks fitted to both the vent valve and pig trap closure, a key is released when the vent valve is opened – removing the key from the vent valve locks the valve in the open position. This key is coded in common with the closure lock – only by opening and locking the vent valve can the operator secure the correct key to proceed to unlock and open the closure.

# PIG TRAP SCHEMATIC AND SEQUENCE

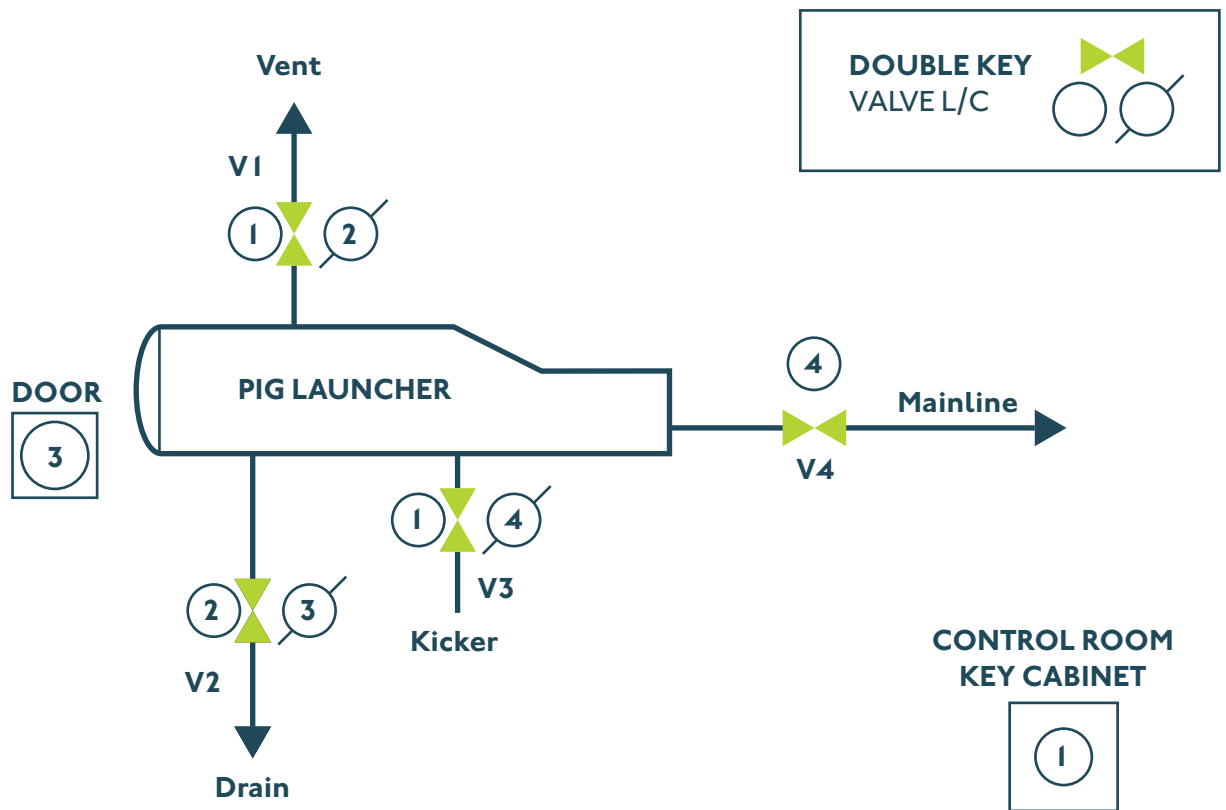

## System Start Condition,

- All valves are closed and locked closed
- Vessel door closed & locked closed
- Key 1 is located in the Control Room Key Cabinet.

### 1 To Load Pig(s)

- Insert Key 1 into V1, unlock and open, lock open by releasing key 2.
- Key 2 into V2, unlock and open, lock open by releasing key 3.
- Key 3 into door lock. Unlock and open the vessel door, key 3 is retained all the time the door is unlocked and/or opened.

\*Load Pigs\*

### 2 To Re-Isolate, pressurise then launch

- Close and lock closed the vessel door, key 3 is released.
- Key 3 into V2, unlock and close, lock closed by releasing Key 2.
- Key 2 into V1, unlock and close, lock closed by releasing Key 1.
- Key into V3, unlock and open, lock open by releasing key 4.
- Key 4 into V4, unlock and open.

\*Pig(s) Launched\*

### 3 Re-Isolate after launch

- Close lock by releasing key 4.
- Key 4 into V3, unlock and close, lock closed by releasing key 1.

### 4 Depressurise Trap

- Key 1 into V1, unlock and open, Lock open by releasing key 2.
- Key 2 into V2, unlock and open, Lock open by releasing key 3.
- Key 3 into V2, unlock and close, lock closed by releasing key 2.
- Key 2 into V1, unlock and close, Lock closed by releasing key 1.

### 5 To Leave Trap in 'Dormant/Start' Condition

- Key 1 is returned to the Control Room Key Cabinet.

\*Proposed Sequence Ends\*

# PIG TRAP INTERLOCKING

‘...Imagine the consequences of opening a Pig Trap closure with product and or pressure in the barrel’

‘...Imagine the effect of attempting to pass a pig through a partially open outlet valve’

‘...Imagine being exposed to H<sub>2</sub>S’

**...These things can happen - have happened!**



Various switch options are available for the SFC DL3 interlock, should additional indications of the door/closure status be desired.

## MECHANICAL KEY SAFETY

Mechanical key safety interlocking is the **ONLY** technology that can assure the universally accepted requirement in the loading and unloading of pig traps that the vessel is vented **BEFORE** it is possible to open the vessel closure. A key is released when the vent valve is unlocked and opened which then enables unlocking of the closure mechanism. This imperative is defined variously in the following standards and regulations:-

### ASME VIII - Appendix M

1996 No. 825 - (UK) Pipeline Safety Regulations (Section 6 - Para. 37 of Guidance on Regulations - UK Health & Safety Executive).

US DoT - Pipeline Safety Regulations - Part 195 Transportation of Hazardous Liquids by Pipeline (§195.426 Scraper & Sphere Facilities).

Shell DEP 31.40.10.13 - Gen : Design of Pipeline Pig Trap Systems.

Other major OpCos including Statoil, Hydro, ADCO & BP among others have well defined specification requirements for interlocking of their launchers and receivers.



# SITE SERVICES

**The vast knowledge and experience of our Site Service Team cannot be over stated.**

Smith Flow Control employ a team of highly qualified Site Service Technicians with years of experience working all around the world – both onshore and offshore.

With an in-depth technical understanding of valve interlocking, drive systems and services, coupled with a passion for safety, compliance and quality, the team is committed to doing things the right way and offering a service which is second to none.

Our Site Service Team can provide onsite support, guidance, supervision and project management of all installations, offering a full turnkey service, through to final sign off with the client.

## SURVEY

---

SFC Site Service Engineers are available upon request to help obtain the detailed ‘top-work’ dimensions. These measurements are a crucial component of the design process, which results in the provision of an interlock which is fit for purpose and is right first time, preventing delays and saving the customer both time and money.

## HEALTH CHECK

---

SFC valve interlocks are not maintenance intensive but an annual systems health check on condition is recommended to ensure longevity of equipment where used correctly. General wear and tear and environmental conditions may affect the integrity but a routine service avoids unplanned maintenance and shut downs. A tailored, customized package can be offered to include surveying, functionality checks and inspections of locks.

## TRAINING

---

Training is an integral part of our operation. SFC will work seamlessly with your team to ensure the smooth and optimized performance of your equipment. Training is recommended to ensure correct application/operation, which can be provided at site or in house. This will cover fundamental points, to include setting and re-setting of valve interlocks, equipping engineers with the knowledge required for successful operations.

## INSTALLATION, COMMISSIONING & HANDOVER

---

SFC Site Service Engineers are experts in installing interlocks, which have been designed and manufactured to bespoke specifications. The correct setting and operation of valves is crucial to ensure operational safety and efficiency. SFC’s dedicated team of Site Service Engineers will ensure your equipment is installed, commissioned and handed over, with complete peace of mind.





## SFC REPRESENTATION AROUND THE WORLD

---

We supply and support some of the worlds biggest companies involved in the Oil & Gas and Petro-Chemical industries. Since our formation in 1985 we have partnered most of the worlds leading Oil & Gas producers and chemical processors by developing and delivering innovative engineering solutions to manage and protect their multi-billion dollar field asset investments.

**Our clients rely on our engineering expertise and product reliability to assure standards of operating safety demanded in modern society. We remain focused on the continuous task of meeting and exceeding those demands.**

As part of a process of on-going product development, Smith Flow Control reserves the right to amend and change specifications without prior notice.

Published data may be subject to change.

For the very latest version release, visit our website at [www.smithflowcontrol.com](http://www.smithflowcontrol.com)



Smith Flow Control Ltd  
6 Waterside Business Park  
Eastways Industrial Estate  
Witham Essex CM8 3YQ  
United Kingdom

Tel: +44 (0)1376 517901

Fax: +44 (0)1376 518720

[sales@smithflowcontrol.com](mailto:sales@smithflowcontrol.com)

[www.smithflowcontrol.com](http://www.smithflowcontrol.com)