

PROVIDING SAFETY

WIJ BESCHERMEN
uw meest belangrijke kapitaal
UW MEDEWERKERS



SSP Safety System Products GmbH & Co. KG
Zeppelinweg 4
D-78549 Spaichingen
www.safety-products.de

This operating instruction is an original operating instruction. All rights, errors and changes reserved.

As a supplement to this operating instruction, optional functions will be provided in the form of supplements corresponding to the equipment of your machine.

1000308
Version 4.0
March 2020



SAFIX 3
Safety Switch



Table of Contents

1 About this document	2	4 Electrical connection	5
1.1 Function.....	2	4.1 General notes on the electrical connection.....	5
1.2 Safety note for authorized qualified personnel.....	2	4.2 Requirements for the downstream evaluation.....	5
1.3 Symbols.....	2	4.3 Configuration safety control.....	5
1.4 Field of application.....	2	5 Effect and coding	5
1.5 Note: Safety notes.....	2	5.1 Functioning of the safety outputs.....	5
1.6 Note: Incorrect usage.....	2	5.2 Safety inputs.....	5
1.7 Liability exclusion.....	2	5.3 EDM input.....	5
2 Product description	2	6 Diagnosis output	6
2.1 Proper usage.....	2	6.1 Diagnosis output.....	6
2.2 Designs.....	2	6.2 LED display, blink codes and clocking diagnosis output.....	6
2.3 Special types.....	2	7 Commissioning and maintenance	6
2.4 Effects.....	2	7.1 Functional test.....	6
2.5 Series connection.....	2	7.2 Learning process for variation "Individual, retrainable".....	6
2.6 Approvals.....	3	7.3 Maintenance.....	6
2.7 Safety appraisal.....	3	7.4 Damaged or defective machines.....	7
2.8 Manipulation protection according to ISO 14119.....	3	7.5 Troubleshooting.....	7
2.9 Technical data.....	3	8 Disassembly and disposal	7
3 Assembly	4	8.1 Uninstallation.....	7
3.1 General assembly notes.....	4	8.2 Disposal.....	7
3.2 Dimensions.....	4	9 Annex	7
3.3 Assembly instruction.....	4	9.1 Wiring examples.....	7
3.4 Approach directions.....	4	9.2 Pin assignment.....	9
3.5 Switching distance.....	4	10 Accessories	9
		10.1 Accessories for SAFIX 3.....	9
		11 Declaration of Conformity	10
		11.1 EC Conformity Regulation.....	10

1. About this document

1.1 Function

This operating instruction provides the required information for the assembly, installation, safe operation and uninstallation of the RFID safety sensor SAFIX. The operating instruction must always be stored accessible and in a legible state for the lifespan of the machine and must be read carefully before usage. The operating instruction must be shared with every subsequent owner and user of the machine. It must be updated in the event of any supplement received from the manufacturer.

1.2 Safety note for authorized qualified personnel

The handling described in this operating instruction may only be executed by trained qualified personnel authorized by the plant operator. Read and understand the operating instruction before you operate SAFIX. Familiarize yourself with the applicable provisions about work safety and accident prevention. The (inter)national legal provisions apply for the assembly and installation as well as regular technical inspections.

1.3 Symbols



Caution

Not complying with the warning notes may result in disruptions or malfunctions; furthermore, people and/or machines may suffer damage.



information

Helpful additional information

1.4 Field of application

The products described here were developed to be accepted as a part of a total plant or machine for safety relevant applications in process and automation technology. The manufacture of a plant or machine is responsible for guaranteeing the correct overall function. The safety switch machine may only be used corresponding to the following statements or for applications approved by the manufacturer. Detailed information about the area of application can be found in Chapter 2. Product description".

1.5 Note: Safety notes

The safety notes for the operating instruction, identified through the symbol above for caution or warning, as well as country-specific installation, safety and accident prevention provisions must be complied with. Please find further technical information in the SSP data sheets online at www.safety-products.de.

All information is supplied without guarantee. Subject to changes that serve for technical progress. If the notes on safety and instructions regarding assembly, installation, operation and maintenance are followed, no residual risks are known.

1.6 Note: Incorrect usage

In the event of an improper or incorrect usage or manipulations, hazards for people or damage to the machines or plant parts cannot be ruled out through the usage of safety switchgear. Spare parts or accessories that are not explicitly approved by the manufacturer may not be used with SAIFX. Please also observe the notes regarding this found in standard ISO 14119.

1.7 Liability exclusion

No liability will be taken over for damage and operating disruptions that arise through assembly mistakes or non-compliance with this operating instruction. For damage that results from the usage of spare parts or accessories not approved by the manufacturer, the manufacturer's liability is ruled out completely. All independent repairs, conversions and changes are not permitted due to safety reasons and rule out the manufacturer's liability for any damage resulting from this.

2. Product description

2.1 Proper usage

The machine is designated solely for industrial usage. The non-contact, electronic safety sensor is designed for usage in safety circuits and serves to monitor the position of moving protection equipment.

2.2 Designs

This operating instruction is valid for the following designs:

Model code	SAFIX ① 3-② - ③
① Coding variation	
S	Standard coding
I	Individual coding
W	Individual coding, reteachable
② EDM input variation	
A	EDM input automatic
X	EDM input monitored (start button)
③ Connection variation	
P	Plug M12 x 1, 8-pin, pigtail 185 mm
3M	Connection cable, 8 x 0.34 mm ² , 3 m
5M	Connection cable, 8 x 0.34 mm ² , 5 m
10M	Connection cable, 8 x 0.34 mm ² , 10 m

Actuator

SAFIX T5	Coded
----------	-------

2.3 Special types

Both the previously named specifications and those in the following apply for special types that are not listed in the type key under point 2.2, provided these agree with the serial design.

2.4 Effects

Coded, electronic safety sensor that is activated without touch through a coded actuator. The safety sensor monitors the position of rotating, sliding or also removable protection equipment with the coded electronic actuator.

The safety function allows for the safe shut down of the safety outputs when opening the protection equipment and guarantees that safety outputs remain shut down if the protective equipment is opened. As a digital output, the diagnosis output from the safety sensor delivers information about the state of the sensor.

This may occur in connection with an SSP safety analysis unit or comparable safety controls.

The analysis logics integrated in the sensor as well as an EDM input can use the sensor without additional safety analysis units/controls as well.



The total concept of the control in which the safety component is integrated must be verified according to the relevant standards.

2.5 Series connection

The safety sensors permit a series connection with up to 30 sensors upon simultaneously reaching of up to PL e with correct wiring. With a series connection, it must be considered that time delays may add up for each sensor. You can find the corresponding technical data from the table under point 2.9.

See point 5.3 for information about the EDM input.

You can find wiring examples under point 9.1. Other wiring examples, for example, with our passive distributor XCONN, can be downloaded from our website at www.safety-products.de. The maximum number of safety sensors as well as the total length of the sensor chain are depending on the load. The voltage drop in the system increases with increasing wire length and increasing power load (load + sensors) in the series connection. If the permissible value of 21.6 V is not met, a new feed must be provided.

2.6 Approvals

TÜV Süd
UL E470178,
SLG inspects according to ECOLAB for the chemical resistance against the following cleaning agents: Distilled water, P3-topax 66, P3-topactive 200, P3-topax 52, P3-topax 990

2.7 Safety appraisal

Performance Level PL e	EN ISO 13849-1:2008-12
SIL 3	IEC 61508:2010
SILCIL 3	IEC 62061:2005+A1:2013
PFH _d 2.21 x 10 ⁻⁹	IEC 61508:2010
Category 4	EN ISO 13849-1:2008-12
Structure	two-channel
HFT	1
Usage duration	20 years

2.8 Manipulation protection according to ISO 14119

Standard coding

The safety sensor accepts every SAFIX T5 actuator of the type 4, low coding level in accordance with EN ISO 14119.

Individual coding

The safety switch only accepts the SAFIX T5 actuators included in the delivery. The pair of the sensor and actuator cannot be separated; if a component is lost and not functional, both components must be replaced. Type 4, high coding level in accordance with EN ISO 14119.

Individual coding, reteachable

The safety sensor accepts a SAFIX T5 actuator. This actuator is taught on the safety sensor; an unsuitable actuator in the recording area of the sensor leads to an error. Teaching a new actuator is possible without any limitations and is described in detail under point 7.2. Type 4, high coding level in accordance with EN ISO 14119.

2.9 Technical data

Function type RFID safety switch

Safety technical data

Performance Level (EN ISO 13849-1)	PL e
SIL	SIL3, SILCL3
Category (EN ISO 13849)	Cat. 4
Stop category (EN 60204-1)	
Usage duration TM (EN ISO 13849-1)	20 years
PFH _d (EN ISO 13849)	2.24 x 10 ⁻⁹

Ambient conditions

Storage temperature max.	-25 ... + 70 °C
Operating temperature max.	- 25 ... + 70 °C
- Cable variation	+ 60 °C
- Plug variation	+ 45 °C
Cable temperature range mobile	- 5 ... + 80 °C
Cable temperature permanently installed	-30 ... + 80 °C

Air and creepage distances according to IEC/EN 606641

Assessment surge electric strength Uimp	1000 V
- Overvoltage category	II
- Degree of contamination	2
Relative humidity	5 ... 85%
Air pressure	860 ... 1060 hPa
Δtmax	0.5 °C/min

Electrical data

Contact type	OSSD
Supply voltage UB	24 V DC +/- 10%
Assessment insulation voltage Ui	50 V
Power consumption	23.75 W
No-load current IO	10 mA (not activated)/30 mA (activated)
Rated current max.	1A
recommended fuse	quick
Current consumption per input max.	2.75 mA
Switch frequency	3 Hz
Switch current per safety output max.	400 mA
Switch current diagnosis output max.	50 mA
Remaining current (Ir)	0.5 mA
Voltage drop (d) outputs	0.75 V

Number of safety outputs	2
Number of control outputs electronic	1
Number of safety inputs	2
Load capacity max.	20 nF
LED lighting	3 colors
Connection variation	Cable or pigtail
Utilization category	D-12/DC-13
Protection rating power supply	III
EDM input automatic	SAFIX __-A-__
EDM input monitored (start button)	SAFIX __-X-__

Mechanical data

Dimensions (L x W x H)	
- Width	36 mm
- Length	13 mm
- Height	26 mm
Weight	135 g (incl. 3 m cable)/45 g (pigtail type)
Torque (mounting nut)	0.7 Nm
Fastening	Bolting with M4 screws (flush)
Protection rating	IP67, IP6K9K(does not apply to plugs)
Material casing	PBT
Material cover	PC
Shock resistance	30 g/11 ms
Vibration resistance	10 ... 55 Hz, amplitude 1 mm
Series connection max	30
Switching distance Sn	12 mm
Minimum switching distance S0min	0.5 mm
Offset actuator	+/- 8 mm
secured switching distance ON Sao	DIN EN 60947-5-3:2014-12
secured switching distance OFF Sar	DIN EN 60947-5-3:2014-12
Assessment switching distance S0 min)	DIN EN 60947-5-3:2014-12
Hysteresis	2 mm
Repetition accuracy R	< 0.5 mm
Times	
Readiness delay time (tv)	1000 ms
Switch-on delay (ton)	75 ms
Response time	75 ms
Shut-down delay (toff) inputs max.	3 ms
Shut-down delay (toff) actuators max.	75 ms
Max. test impulse length safety outputs	0.3 ms

Note



The sensor must be directly or indirectly supplied with an SELV/PELV power supply. A voltage supply with the characteristics "for use in class 2 circuits" must be used for implementation and usage in accordance with the requirements 1).

Note



Regarding the scope of the UL approval: The devices were inspected in accordance with the requirements from UL508 and CSA/ C22.2 no. 14 (protection against electrical shock and fire).

3. Assembly

3.1 General assembly notes

The requirements of the standard ISO 14119 must be considered during assembly.



Precautionary measures during installation

Follow these instructions to avoid injuries or damage to the equipment.

The mounting holes permit double-sided assembly options through M4 screws (max. tightening torque 0.7 Nm).

Screws made of non-ferromagnetic material (for example, brass) must be used. The mounting position is not important. However, the safety sensor and actuator must be mounted parallel to each other.

The safety sensor may only be used in the secured switching distances. The safety sensor and actuator must be permanently mounted to the protection equipment and secured against moving through appropriate measures (usage of non-removable screws, gluing, drilling screw heads, pins). In order to avoid influence caused by the system and a reduction of the switching distances, please observe the following notes:

- Metal parts near the sensor may change the switching distance.
- Keep metal chips away
- Minimum distance between two safety sensors: 150 mm



In order to secure the mounting screws against simple disassembly, we recommend using the screw covers included in the delivery.

3.2 Dimensions

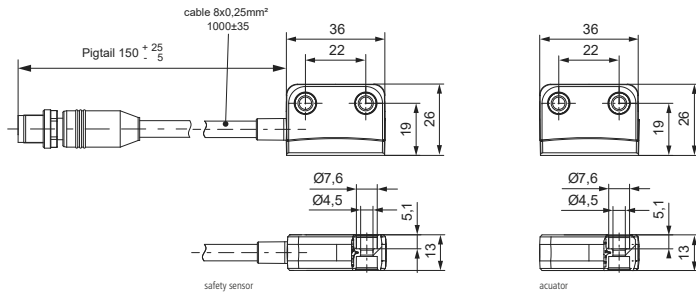

Figure 1: Dimension in mm

3.3 Assembly instruction

The safety sensor may only be installed on flat surfaces.

- The connection wire from the safety sensor must be laid so that it is protected against mechanical damage.
- Consider the requirements of EN 60204-1, in particular regarding suitable installation, during assembly. It is recommended to install the sensor wire so that it is covered.

Accessories (to be ordered separately)

Set of non-removable screws

- SAFIX Z S20: 4 pieces M4x20 incl. washers, SP-K-71-000-00
- SAFIX Z S25: 4 pieces M4x25 incl. washers, SP-K-71-000-01

Seal set

- included in the delivery
- Plug: 4 units flat for flush closure
- for sealing assembly drill holes:

Flush non-removable plugs for flat screw heads also suitable for manipulation protection of the screw mounts

3.4 Approach directions

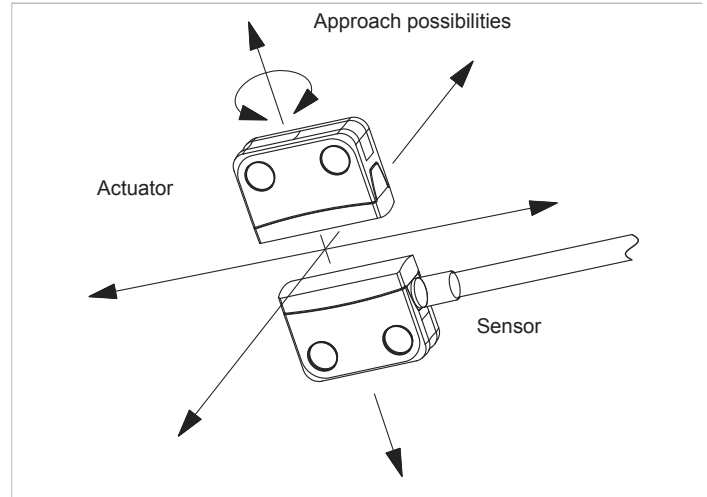

Figure 3: Control possibilities

3.5 Switching distance

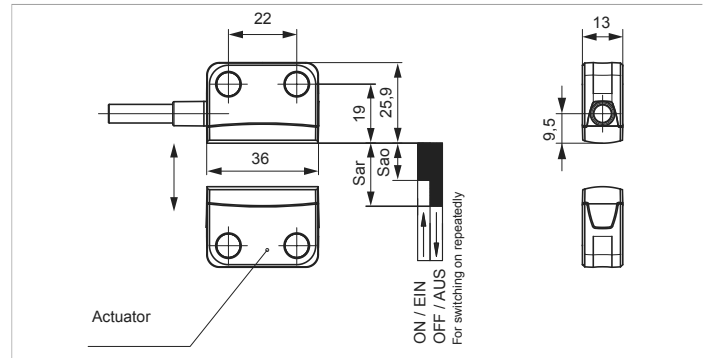

Figure 4: Switching distance

Threshold monitoring

If the actuator is located in the threshold of the switching distances (see point 2.9 Technical Data) with the corresponding offset values of the sensor, this will be transferred to an SPS or displayed through the LED, see point 6.2.

Adjustment

The specified switching distances (see point 2.9 Technical Data) only apply to assembly on non-metallic material if the safety sensor and actuator are mounted parallel to each other. Other arrangements may lead to deviating switching distances.

4. Electrical connection

4.1 General notes on the electrical connection

The electrical connection may only be executed in a state without voltage and by an authorized expert. The safety outputs may be used directly for the wiring in the safety-relevant part of the user control. For requirements in PL e / category 4 in accordance with ISO 13849-1, the safety outputs from the safety sensor or the sensor chain must be kept at an analysis with the same category.



Both safety outputs must always be evaluated to guarantee safety. Since the diagnosis output is not a safety output, it may not be used for safety-relevant reporting and controlling functions.

4.2 Requirements for the downstream evaluation

Two-channel safety input, suitable for p-switching sensors with closer function.

Possible analysis units from SSP:

- Safety Simplifier
- Safety relay series S
- Safety relay series E (with EDM function SAFIX __-X-__)
- MOSAIC M1

If the safety sensor is connected with the relay or with unsecured control components, a new risk assessment must be executed. The sensors test their safety outputs through cyclical shut down. A cross-wire monitoring in the analysis is therefore not required. The shut-down times must be tolerated by the analysis. The shut-down time of the safety sensor extends additionally depending on the wire length and the capacity of the wire being used.

4.3 Configuration safety control

- Do not use a control with test impulses or turn off the test impulses from your control. The machine creates its own test impulses on the safety outputs. A downstream control must tolerate these test impulses, which may have a length of up to 0,3 ms. Depending on the inertia of the downstream machine (control, relay, etc.), this may lead to short switching processes.
- The inputs from a connected analysis device must enable positive switching, because the two outputs of the safety switch delivery a level of +24 V DC when turned on.

5. Effect and coding

5.1 Functioning of the safety outputs

The safety sensor has 2 outputs secured against short-circuits (OSSD), which may switch a max. load of 400 mA per channel. The safety outputs connect under the following conditions:

- the correct actuator is recognized in the contact area (protection equipment closed)
- a high signal is present on both safety inputs
- the EDM input is correctly set
- no error is detected

The safety sensors disconnect under the following conditions:

- there is no or an incorrect actuator in the detection area
- a low signal is present on one of the two inputs
- an error is detected

The two safety outputs may be connected to the inputs from a secure control under the following prerequisites:

- the input must be suitable for clocked safety signals (OSSD signals); the control must tolerate test impulses on the input signals (see Technical Data point 2.9). Observe the notes from the control manufacturer.

You can find wiring examples under point 9.1.

5.2 Safety inputs

The safety sensor has 2 safety inputs.

- during the sole usage of the sensor, connect the safety inputs to +24 V DC
- when using the sensor in a series connection, the safety inputs from the first sensor are connected to +24 V DC - the safety inputs from the following sensors are connected with the safety outputs of the previous sensor. Observe also point 4.4. Series Connection for this. - Pulses with a duration of max. 900 µs are tolerated on the safety inputs.

You can find wiring examples under point 9.1.

5.3 EDM input (External Device Monitoring)

The EDM input is included in two different version, once as "automatic" (SAFIX __-A-__) and once as "monitored" (SAFIX __-X-__), please consult the type key under point 2.2 for exact descriptions.

If the EDM input is not required, the input must be connected to +24 V DC.

EDM input: automatic

During protection monitoring, the opener contacts of the protection must be connected to the EDM input. For a series connection with multiple sensors, all EDM inputs must be connected to +24 V DC. The monitoring of the protection must be connected to the last sensor of the chain. You can find wiring examples under point 9.1.

EDM input: monitored (start button)

Connect an external start button from your machine control to the EDM input. The EDM input is only detected as correctly set if at least one valid start pulses is detected after the sensor is activated and the safety inputs are set. The valid start pulse is detected if a falling flank is detected within the permissible start pulse duration between 30 ms and 5 s following an increasing flank. You can find wiring examples under point 9.1.

6. Diagnosis output

6.1 Diagnosis output

The diagnosis output is positive switching and short-circuit resistant and transmits the different sensors states using different signals, for example, to an SPS. The pulsed signals correspond to the clocking of the yellow LED. The different signals are described in detail under point 6.2.

6.2 LED display, blink codes and clocking diagnosis output

Sensor not activated

LED green	off
LED red	off
LED yellow	on
Diagnosis output	0 V
Safety outputs	0 V
Comment	Voltage is present

Actuator in the detection area

(sensor activated), all inputs set correctly

LED green	on
LED red	off
LED yellow	off
Diagnosis output	24 V DC
Safety outputs	24 V
Comment	Actuator in the detection area

Actuator in the detection area

(sensor activated), safety inputs not set (low level)

LED green	blinks ¹⁾
LED red	off
LED yellow	off
Diagnosis output	24 V DC
Safety outputs	0 V
Comment	Set safety inputs

Actuator in the detection area (sensor activated),

Safety inputs set (high level), waiting for start pulse

LED green	flashes ²⁾
LED red	off
LED yellow	off
Diagnosis output	24 V DC
Safety outputs	0 V
Comment	Press start button

Actuator at the border of reception

LED green	off
LED red	off
LED yellow	blinks ¹⁾
Diagnosis output	24 V DC clocked
Safety outputs	Previous state
Comment	Adjust sensor

Learning process

LED green	off
LED red	off
LED yellow	flashes ²⁾
Diagnosis output	24 V DC clocked
Safety outputs	0 V
Comment	turn off voltage to complete learning

Error state

LED green	off
LED red	blinks ¹⁾
LED yellow	off
Diagnosis output	0 V
Safety outputs	0 V
Comment	See "Troubleshooting" on page 5.

1) Blinking: The impulse break ratio of the LED is 1:1.

2) Flashing: The impulse break ratio of the LED is 1:5.

7. Commissioning and maintenance

7.1 Functional test

The safety switch device must be tested regarding its safety function. The following must be guaranteed in advance:

1. Solid seating of safety sensor and actuator.
2. Solid seating and intactness of the feed.
3. The system is free of all contamination (in particular metal chips).



Note

Damaged or defective machines may not be operated!

7.2 Learning process for variation "Individual, retrainable"

The first permissible actuator is detected immediately after connecting the voltage supply if it is also located in the detection area of the sensor. All remaining teaching of an actuator must occur as described in the following:

1. Connect supply voltage to the safety sensor.
 2. Bring a permissible actuator into the sensor's detection area.
 3. The actuator is recognized, the red LED blinks six times.
 4. The LED will begin to flash yellow after 10 s.
 5. Turn off the supply voltage within the next 2 minutes.
 6. Reconnect supply voltage, then the teaching process is complete and the actuator will be accepted.
 7. If a new actuator is being taught, the safety sensor will block the code of the last predecessor; this is no longer permissible.
 8. Do not remove the actuator during the process as long as it is in the detection area.
- If the teaching process is canceled, the supply voltage must be turned off and the process restarted. The teaching of actuators on a safety sensor is possible an infinite number of times, provided that the code from the actuator is not blocked in the sensor.

8.1 Maintenance

The safety sensor does not require maintenance if it is properly installed and used. We recommend performing a visual and functional inspect in regular intervals with the following steps:

1. Check the safety sensor, actuator and wire for integrity and solid fitting.
2. Remove any metal chips.

8.2 Damaged or defective machines

Damaged or defective machines must be replaced with original spare parts!
 For the "Individual" variation, the safety sensor AND actuator must be replaced.
 With the "Individually reteachable" variation, the teaching process must be performed during the replacement of the safety sensor OR actuator.



8.3 Troubleshooting

Blink code of the red LED

Error safety outputs

Flash pulse	 1 pulse
Cause	Short circuit between safety outputs, against mass or against +24 V DC. Wire break.
Repair	<ul style="list-style-type: none"> • Turn off voltage supply • Repair short-circuit/wire break on the output • Reconnect supply voltage

Error safety inputs

Flash pulse	 2 pulses
Cause	Short circuit between safety inputs, against mass or against +24 V DC. Only one of two safety inputs available. Wire break.
Repair	<ul style="list-style-type: none"> • Turn off voltage supply • Repair short-circuit/wire break on the input • Reconnect supply voltage
Flash pulse	 3 pulses
Cause	<ul style="list-style-type: none"> • EDM automatic: Error on connected safety relay • EDM manual: Start impulse not in defined range • Independent of variation: Wire break
Repair	<ul style="list-style-type: none"> • Turn off voltage supply • Check safety relay or correctly set start impulse, check for wire break • Reconnect supply voltage

Error over or under voltage

Flash pulse	 4 pulses
Cause	The supply voltage was not connected in the defined area.
Repair	<ul style="list-style-type: none"> • Turn off voltage supply • Guarantee correct voltage supply and reconnect

Temperature outside of permissible range

Flash pulse	 5 pulses
Cause	The defined temperature range was not met or was exceeded.
Repair	<ul style="list-style-type: none"> • Turn off voltage supply • Repair short-circuit/wire break on the output • Reconnect supply voltage

Wrong actuator

Flash pulse	 6 pulses
Cause	Incorrect actuator in the detection area of the sensor.
Repair	<ul style="list-style-type: none"> • Use correct actuator

Internal device error

Flash pulse	 permanent light
Cause	Internal device error.
Repair	<ul style="list-style-type: none"> • Turn off voltage supply and reconnect

9. Disassembly and disposal

9.1 Uninstallation

SAFIX may only be disassembled when it has no voltage.

9.2 Disposal

SAFIX must be properly disposed of corresponding to the national and regional provisions and laws.

10. Annex

10.1 Wiring examples



Note:

The illustrated examples are only suggestions. The user must create the task for the entire system according to the applicable standards and provisions.

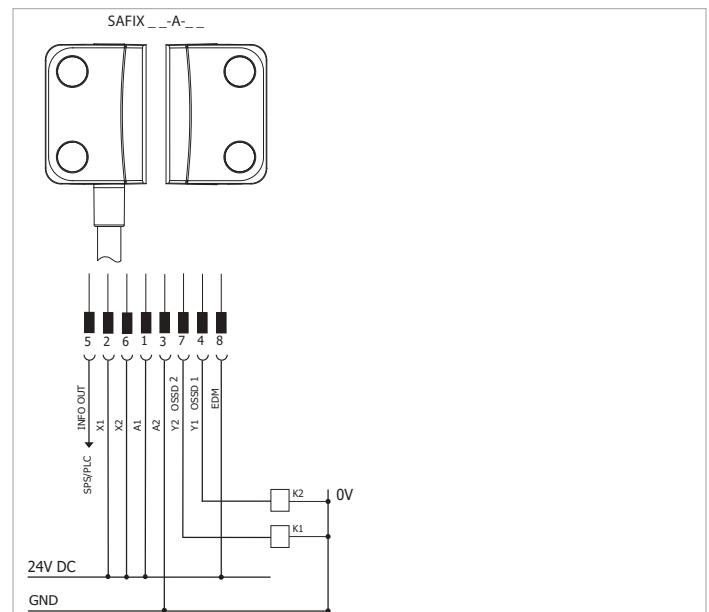

Figure 5: Connection with diagnosis output, automatic reset
 Automatic for the EMD input variation (SAFIX __-A-__)

The inputs X1 and X2 are supplied with 24 V DC. The outputs Y1 and Y2 are included in the analysis. The diagnosis output can be connected, for example, to an SPS.

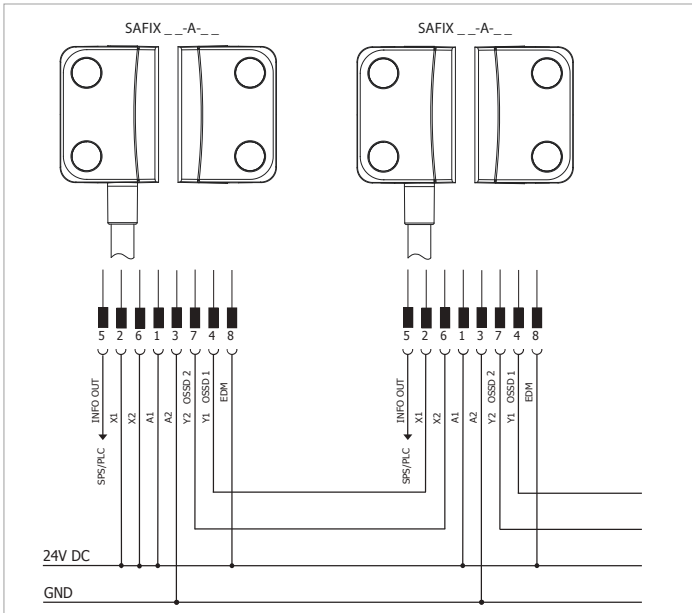

Figure 6: Series connection with diagnosis output, automatic reset
Automatic for the EMD input variation (SAFIX __-A-__)
The inputs X1 and X2 are supplied with 24 V DC. The outputs Y1 and Y2 are included in the analysis. The diagnosis output can be connected, for example, to an SPS.

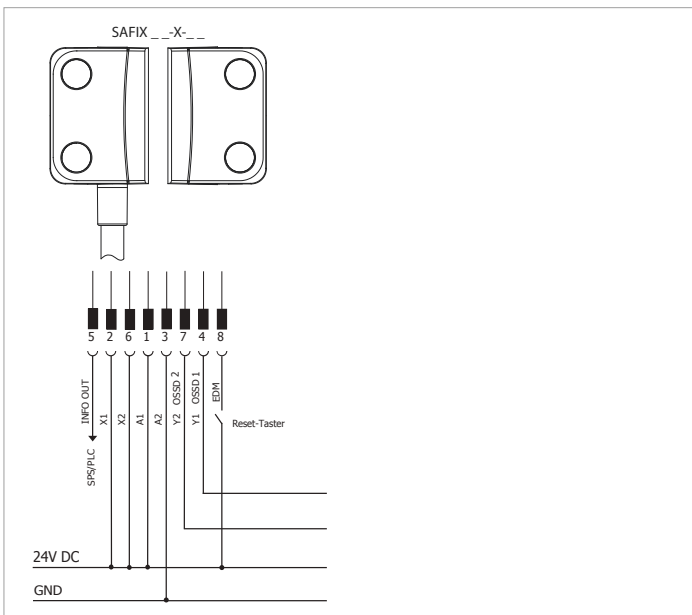

Figure 7: Input from a reset button
Monitored for the EMD input variation (SAFIX __-X-__)
The inputs X1 and X2 are supplied with 24 V DC. The outputs Y1 and Y2 are included in the analysis. The diagnosis output can be connected, for example, to an SPS.
The input EDM waits for a start pulse duration between 30 ms and 5 s.

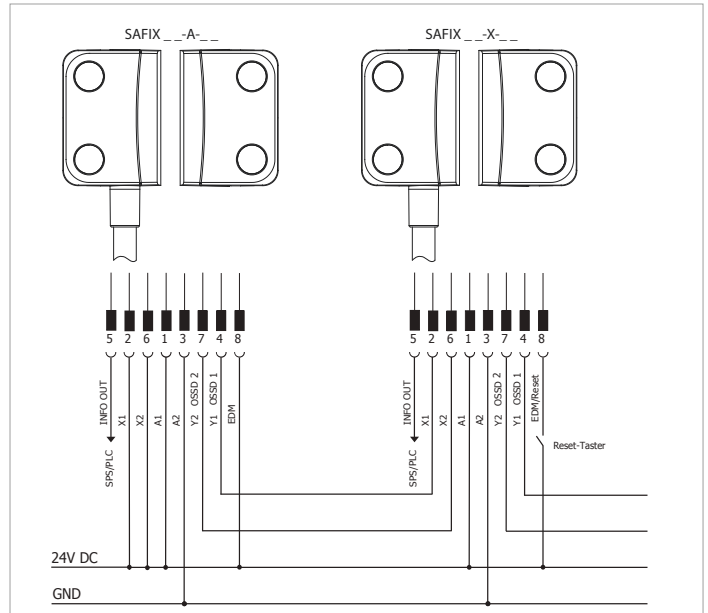

Figure 8: Input from a rest button + every door circuit can be acknowledged, SAFIX __-X-__
Series connection of multiple SAFIX sensors with manual reset.
The reset button always has to be connected to the last sensor. (SAFIX __-X-__)
All other sensors must be used with the automatic start variation (SAFIX __-A-__)

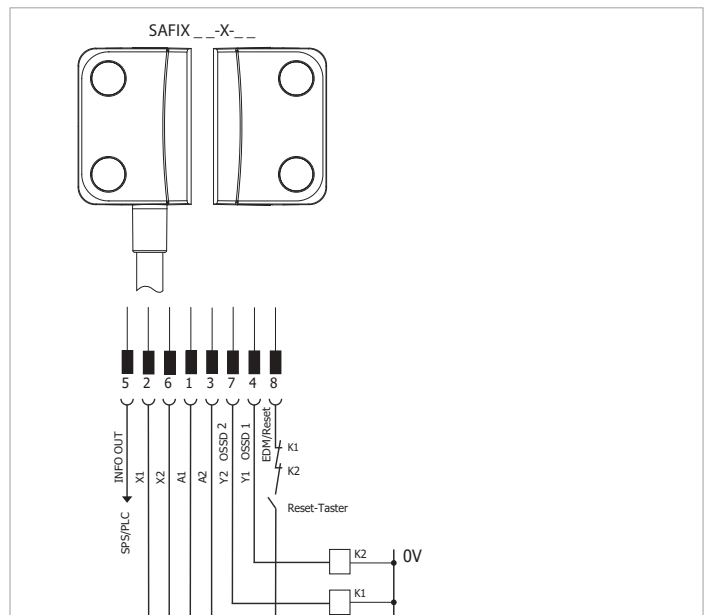

Figure 9: Direct connection of two protections according to PL e, SAFIX __-X-__
The inputs X1 and X2 are supplied with 24 V DC. The outputs Y1 and Y2 are included in the analysis. The diagnosis output can be connected, for example, to an SPS.
The EDM input waits for a start pulse duration between 30 ms and 5 s. The return circuits from protections K1 and K2 are also connected to the EDM input.

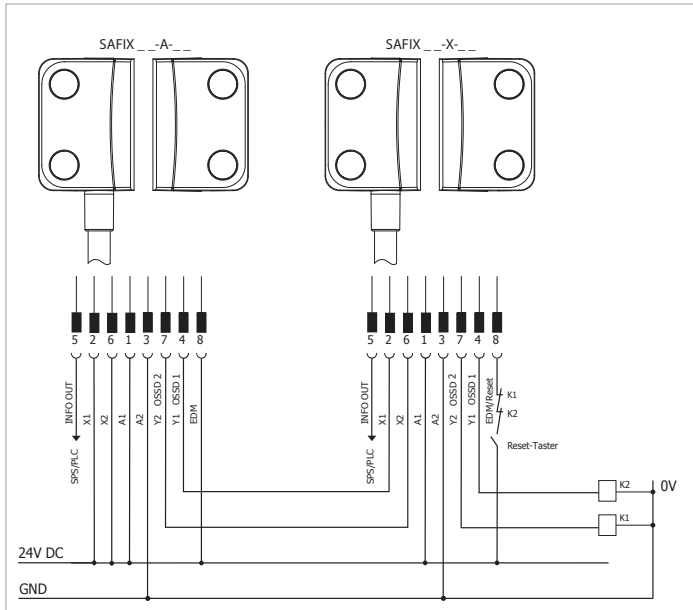

Figure 10: Direct connection of two protections according to PL e, SAFIX __-A-__ & SAFIX __-X-__

The EDM input waits for a start pulse duration between 30 ms and 5 s. The return circuits from protections K1 and K2 are also connected to the EDM input.

10.2 Pin assignment

Electrical data pin assignment

PIN	Color *)	Color **)	Function
1	BN	WH	UB
2	WH	BN	Safety input 1
3	BU	GN	GND
4	BK	YE	Safety output 1
5	GY	GY	Diagnosis output
6	PK	PK	Safety input 2
7	VT	BU	Safety output 2
8	OR	RD	EDM/start entrance

*) Color code in accordance with DIN 471000 (10 m, 5 m cable version and pigtail without SSP accessory cable)

**) Color code in accordance with IEC 60947-5-2:2007 (Pigtail version with SSP accessory cable)

Color code key

Code	Color	Code	Color	Code	Color
BK	black	GN	green	PK	pink
BN	brown	GY	gray	RD	red
BU	blue	OR	orange	VT	violet
WH	white	YE	yellow		

11. Accessories

11.1 Accessories for SAFIX 3

Article	Description	Article number
Cable		
M12, 8-pin, 5 m M12 bushing straight on open end	C8D5	SP-R-13-309-80
M12, 8-pin, 10 m M12 bushing straight on open end	C8D10	SP-R-13-309-81
M12, 8-pin, 15 m M12 bushing straight on open end	C8D15	SP-R-13-309-82
M12, 8-pin, 25 m M12 bushing straight on open end	C8D25	SP-R-13-309-66
M12, 8-pin, 40 m M12 bushing straight on open end	C8D40	SP-R-13-309-67
M12, 8-pin M12-male connector	M12-C82-G	SP-X-33-001-03

12. Declaration of Conformity

12.1 EC Conformity Regulation

EC Conformity Regulation

SSP Safety System Products GmbH & Co. KG
Zeppelinweg 4
78549 Spaichingen
Germany
www.safety-products.de

We hereby declare that the following components correspond to the European directives listed below due to their design and construction.

Description of the component	SAFIX 3
Description	Non-contact safety sensor
The identified products fulfilled the requirements of the directives	Machine directive 2006/42/EC Radio installation directive 2014/53/EU EMV directive 2014/30/EU
Type	see type key
Named position for the type examination	TÜV SÜD Product Service GmbH Riedlerstraße 65 D-80339 München Identification Number: 0123
EC type examination certificate	M6A 16 01 20166 036
Authorized party for the creation of technical documents	Wolfgang Engelhart Zeppelinweg 4 78549 Spaichingen
Place and date of issue	Spaichingen, April 1, 2017



Legally binding signature
Johann Aulila
Managing director



Wolfgang Engelhart
Deputy managing director



Note

You can find the signed EC Conformity Statement on the SSP website:
www.safety-products.de



SSP Safety System Products GmbH & Co. KG

Zeppelinweg 4
78549 Spaichingen
+49 7424 98 049-0
info@ssp.de
www.safety-products.de